



Smart solutions.
Strong relationships.

Energy Efficient AC Motors

IE3 Efficiency Class





Apex Series

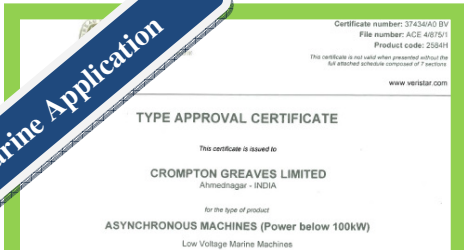

**We put all our energy into saving
yours !**

Marine Application



CE Certificate

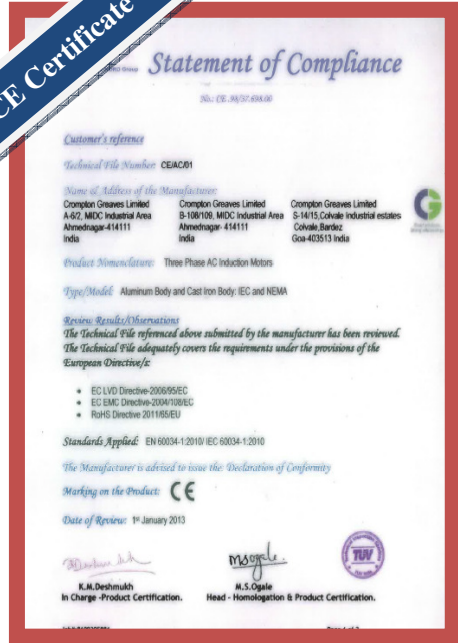

ISO / OHSAS



As one of the world's leading engineering corporations, CG provides end-to-end solutions, helping its customers to use electrical power effectively and increase industrial productivity with sustainability. CG was established in 1937 in India; and, since then the Company has been a pioneer and has retained its leadership position in the management and application of electrical energy.

CG is leading manufacturer of electric motors, with motor solutions which benefits a wide range of customers. Our products are used in almost every industrial application including general manufacturing, petrochemicals, food processing, pharmaceuticals where they drive fans, pumps, compressors, conveyors, lifts and cranes, amongst other thing

CG Apex series IE-3 motors are designed to fulfill the requirement of various applications they also comply to the requirement of IEC 60034:2008, the new harmonized international efficiency standards for three phase induction motors

Motor achieves the benefits by providing energy saving, higher levels of productivity, and extended lifetime operation with minimum maintenance.

Benefits of APEX SERIES motors

Superior aesthetics

APEX series motors are having excellent aesthetics and designed in such a way that provide user with flexibility in the position of main terminal box; on top as standard or on left or right side of the motor as an option.

In aluminum range motors(up to 7.5 kW) : By simply changing the position of the feet, user is able to convert right, left or top terminal box position and by changing the standard end shield user can change it for flange and face version.

Low vibration and low noise

APEX series motors are designed with and to have low vibration and noise , high torque with smooth acceleration throughout the life of the motors, these features makes our motors the most preferred choice for various industrial applications.

Inverter Duty application

APEX series motors are suitable for inverter duty applications*, our insulation system provides key benefit of increasing the dielectric resistance of the motor windings, enabling operation with variable frequency drives.

For protecting the motors from bearing currents a phenomena which is generally observed in frames IEC315 S/M and above, CG recommend/provide insulated bearing for VFD compatible motors.

*for details on VFD operation, please contact CG sales

Other designed features offered CG APEX SERIES

Frames

Frames (cast iron range) are constructed using high grade cast iron, ribbed externally to ensure maximum heat dissipation. All components are machined on CNC that ensures co-planarity of machined surfaces. All components are completely enclosed and air is forced over the stator body by fan, mounted on the shaft and protected by a cowl. The feet are integrally cast with the body. This ensures sturdiness and resistance to vibrations.

Cooling system

APEX SERIES motors are specially design to achieve improved air flow over the motor frames and to maintain low operational temperature and assuring extended life of the motor. APEX SERIES motors comes up with improved aerodynamics that provide effective air flow and minimizing losses due to the recirculation of air between the fan and fan cover.

Shaft and Bearings

The shaft is of high grade steel and of appropriate diameter to withstand the bending and torsional stresses. All shafts are ultrasonically tested for any minor flaw in the material. Shafts are machined to extreme fine limits to ensure fit and interchangeability of bearings. The motors are provided with single shaft extension, we comply to the general requirement of IEC60034, We can offer motors with special shaft on request,

- ◇ Nonstandard diameter and length
- ◇ Taper shaft with threaded end
- ◇ Double shaft extension

Terminal box

CG Apex series motor is fitted with terminal box and gives IP55 degree of protection. The box can be rotated through 360 degree in steps of 90 degree to give cable entry from any of four positions. TB are designed in such a way that provide more space for proper positioning of cable inside terminal box

Standards	Description
IEC 60034-1:2010	Rotating electrical machine-Rating & Performance
IEC 60034-30:2008	Rotating electrical machine-IE code for efficiency classes
IEC 60034-2-1:2007	Rotating electrical machine-Determination of losses & efficiency
IEC 60034-5:2006	Rotating electrical machine-Degrees of protection
IEC 60034-9:2007	Rotating electrical machine-Noise limits
IEC 60034-	Rotating electrical machine-Vibration limits
IEC 60072-1:1991	Rotating electrical machine- Dimension

Reference Standards

Apex Series Aluminum construction motor

Range	
Output	0.75 kW to 7.50 kW
Frames	PA 80 TO PA 132
Poles	2,4,6



Specification

Specification	Standard Product	Option
Frame sizes	80- 132	-
Enclosure	IP55	IP56, IP65, IP66
Mounting option	Foot (B3)	Flange (B5), Face (B14)
Terminal box position	Top	LHS,RHS
Voltage	3 kW and below: 230 / 400,4 kW and above: 400 / 690	-
Frequency	50 Hz	60 Hz
Cooling	IC411	IC410
Lubrication	80 - 132 double-shielded bearings	-
Insulation	Class F	Class H
Temperature rise	Class B	Class F
Paint colour	Yellow green (RAL 6018)	On request
Fan cover	Steel	-
Thermal protection (PTC150)	80— 132	-
Anti condensation heaters	-	132
Inverter Duty (with de-rate)	Variable Torque: 10:1,Constant Torque: 2:1	Alternative speed range
Ambient temperature	- 20°C to + 45°C	- 40°C, up to 60°C

The above specification and options give a brief summary of features available for the Apex series aluminum range.

For a full listing of optional features, please contact CG sales.

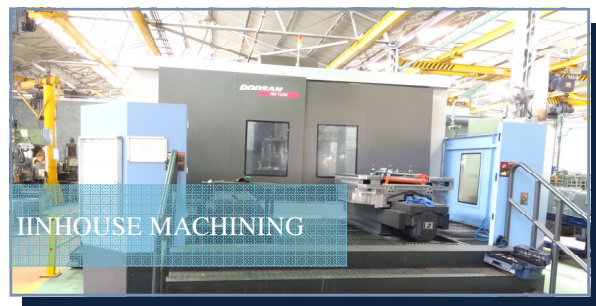

Apex Series Cast Iron construction motor

Range	
Output	0.37 kW to 90 kW
Frames	PC 80 TO PC 280
Poles	2,4,6



Specification

Specification	Standard Product	Option
Frame sizes	80 - 280	-
Enclosure	IP55	IP56, IP65, IP66
Mounting option	Foot (B3)	Flange (B5), Face (B14) up to 132 frame
Terminal box position	Top	LHS,RHS
Voltage	3 kW and below: 230 / 400,4 kW and above: 400 / 690	-
Frequency	50 Hz	60 Hz
Cooling	IC411	IC410
Lubrication	Frame 80 - 225 double-shielded bearings Frame 250 to 280 online greasing	-
Insulation	Class F	Class H
Temperature rise	Class B	Class F
Paint colour	Yellow green (RAL 6018)	On request
Fan cover	Steel	-
Thermal protection (PTC150)	80— 280	
Anti condensation heaters	-	132-280
Inverter Duty (with de-rate)	Variable Torque: 10:1, Constant Torque: 2:1	Alternative speed range
Ambient temperature	- 20°C to + 45°C	- 40°C, up to 60°C

The above specification and options give a brief summary of features available for the Apex series cast iron range.

For a full listing of optional features, please contact CG sales.

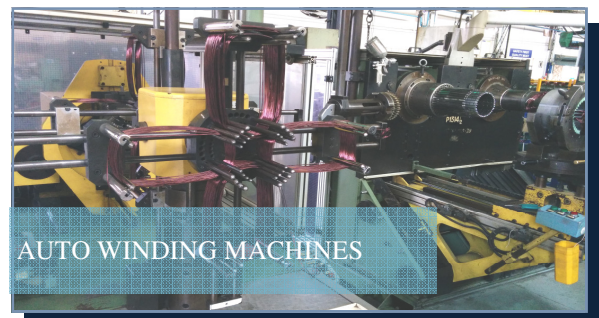

TEFC 3 PHASE FOOT MOUNTED TB ON TOP ALUMINIUM CONSTRUCTION

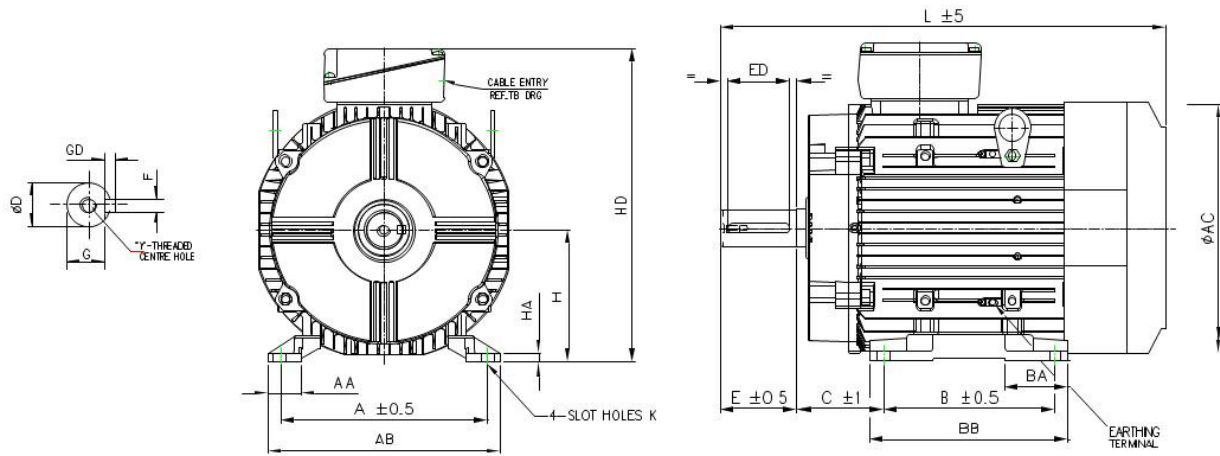

Frame	A	B	C	H	$\frac{A}{A}$	AB	BA	BB	K	D	E	ED	F	GD	G	Y	$\frac{A}{C}$	L	$\frac{H}{D}$	$\frac{H}{A}$
PA80	125	100	50	80.0 / 79.7	30	156	29	127	10x14	19.009 / 18.996	40	32	6.00 / 5.97	6.0 / 5.97	15.5 / 15.3	M6x16	162	330	212	7
PA90S	140	100	56	90.0 / 89.7	30	170	54	150	10x14	24.009 / 23.996	50	40	8.00 / 7.96	7.0 / 6.9	20.0 / 19.8	M8x19	180	365	225	10
PA90L	140	125	56	90.0 / 89.7	30	170	54	150	10x14	24.009 / 23.996	50	40	8.00 / 7.96	7.0 / 6.9	20.0 / 19.8	M8x19	180	365	225	10
PA100L	160	140	63	100.0 / 99.7	35	195	35	170	12x16	28.009 / 27.996	60	50	8.00 / 7.96	7.0 / 6.9	24.0 / 23.8	M10x2 2	210	415	258	11
PA112M	190	140	70	112.0 / 111.7	40	230	60	194	12x20	28.009 / 27.996	60	50	8.00 / 7.96	7.0 / 6.9	24.0 / 23.8	M10x2 2	234	410	282	10
PA132S	216	140	89	132.0 / 131.7	40	256	74	208	12x20	38.018 / 38.002	80	70	10.00 / 9.964	8.0 / 7.9	33.0 / 32.8	M12x2 8	274	485	322	12
PA132M	216	178	89	132.0 / 131.7	40	256	74	208	12x20	38.018 / 38.002	80	70	10.00 / 9.964	8.0 / 7.9	33.0 / 32.8	M12x2 8	274	485	322	12

TEFC 3 PHASE FOOT MOUNTED TB ON SIDE ALUMINIUM CONSTRUCTION MOTOR

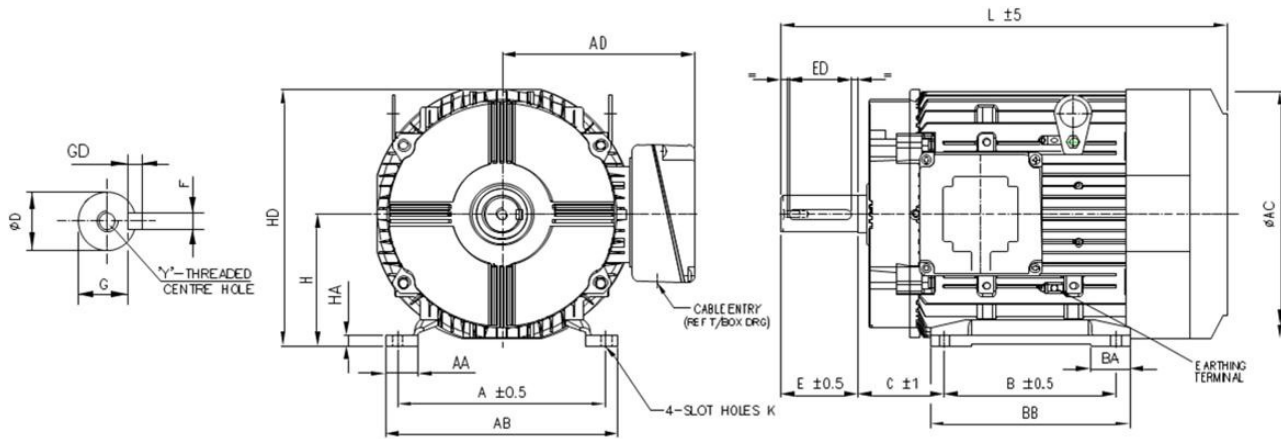

Frame	A	B	C	H	$\frac{A}{A}$	AB	BA	BB	K	D	E	ED	F	GD	G	Y	$\frac{A}{D}$	AC	L	$\frac{H}{D}$	$\frac{H}{A}$
-------	---	---	---	---	---------------	----	----	----	---	---	---	----	---	----	---	---	---------------	----	---	---------------	---------------

POLE : 2,4,6

PA80	125	100	50	80.0 / 79.7	30	156	29	127	10x14	19.009 / 18.996	40	32	6.00 / 5.97	6.0 / 5.97	15.5 / 15.3	M6X16	125	162	330	160	7
PA90S	140	100	56	90.0 / 89.7	30	170	54	150	10x14	24.009 / 23.996	50	40	8.00 / 7.96	7.0 / 6.9	20.0 / 19.8	M8X19	125	180	365	180	10
PA90L	140	125	56	90.0 / 89.7	30	170	54	150	10x14	24.009 / 23.996	50	40	8.00 / 7.96	7.0 / 6.9	20.0 / 19.8	M8X19	135	180	365	180	10
PA100L	160	140	63	100.0 / 99.7	35	195	35	170	12x16	28.009 / 27.996	60	50	8.00 / 7.96	7.0 / 6.9	24.0 / 23.8	M10X2 2	158	210	415	200	11
PA112M	190	140	70	112.0 / 111.7	40	230	60	194	12x20	28.009 / 27.996	60	50	8.00 / 7.96	7.0 / 6.9	24.0 / 23.8	M10X2 2	170	234	410	220	10
PA132S	216	140	89	132.0 / 131.7	40	256	74	208	12x20	38.018 / 38.002	80	70	10.00 / 9.964	8.0 / 7.9	33.0 / 32.8	M12X2 8	190	274	485	260	12
PA132M	216	178	89	132.0 / 131.7	40	256	74	208	12x20	38.018 / 38.002	80	70	10.00 / 9.964	8.0 / 7.9	33.0 / 32.8	M12X2 8	190	274	485	260	12

TEFC 3 PHASE FLANGE MOUNTED ALUMINIUM CONSTRUCTION MOTOR (IMB5)

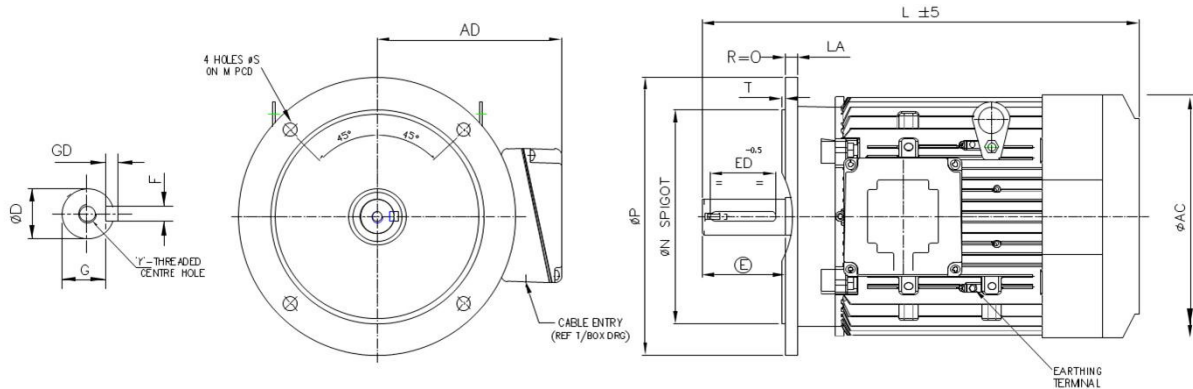

Frame	D	E	ED	F	GD	G	Y	AD	AC	L	M Tol	N Tol	P	S	T	LA	LE
POLE : 2,4,6																	
PA80	19.009 / 18.996	40	32	6.00 / 5.97	6.0 / 5.97	15.5 / 15.3	M6X16	125	162	330	165.3 / 164.7	130.014 /	200	12	3.5	12	85
PA90S	24.009 / 23.996	50	40	8.00 / 7.96	7.0 / 6.9	20.0 / 19.8	M8X19	125	180	365	165.3 / 164.7	130.014 /	200	12	3.5	12	85
PA90L	24.009 / 23.996	50	40	8.00 / 7.96	7.0 / 6.9	20.0 / 19.8	M8X19	135	180	365	165.3 / 164.7	130.014 /	200	12	3.5	12	85
PA100L	28.009 / 27.996	60	50	8.00 / 7.96	7.0 / 6.9	24.0 / 23.8	M10X2 2	158	210	415	215.3 / 214.7	180.014 /	250	14.5	4	14.5	106
PA112M	28.009 / 27.996	60	50	8.00 / 7.96	7.0 / 6.9	24.0 / 23.8	M10X2 2	170	234	410	215.3 / 214.7	180.014 /	250	15	4	12	125
PA132S	38.018 / 38.002	80	70	10.00 / 9.964	8.0 / 7.9	33.0 / 32.8	M12X2 8	190	274	485	265.3 / 264.7	230.016 /	300	15	4	14	130
PA132M	38.018 / 38.002	80	70	10.00 / 9.964	8.0 / 7.9	33.0 / 32.8	M12X2 8	190	274	485	265.3 / 264.7	230.016 /	300	15	4	14	130

TEFC 3 PHASE FACE MOUNTED CAST IRON / ALUMINIUM CONSTRUCTION MOTOR (IMB14)

Frame	M	N	P	S	T	LA
POLE : 2,4,6						
PA/PC80	100	80	120	M6	3	9
PA/PC90S/L	115	95	140	M8	3	9
PA/PC100L	130	110	160	M8	3.5	12
PA/PC112M	130	110	164	M8	3.5	13
PA/PC132S/M	165	130	200	M10	3.5	13

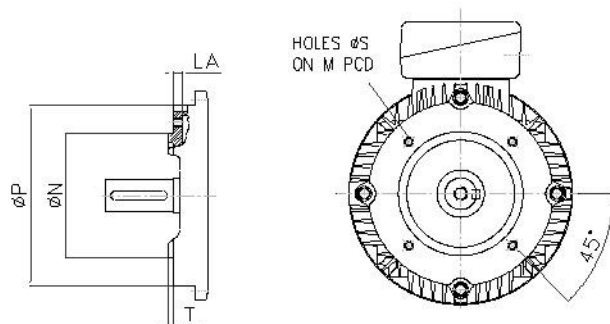

All dimensions are in mm

Some features may be different and may not be a part of standard

TEFC 3 PHASE FOOT MOUNTED TB ON TOP CAST IRON CONSTRUCTION

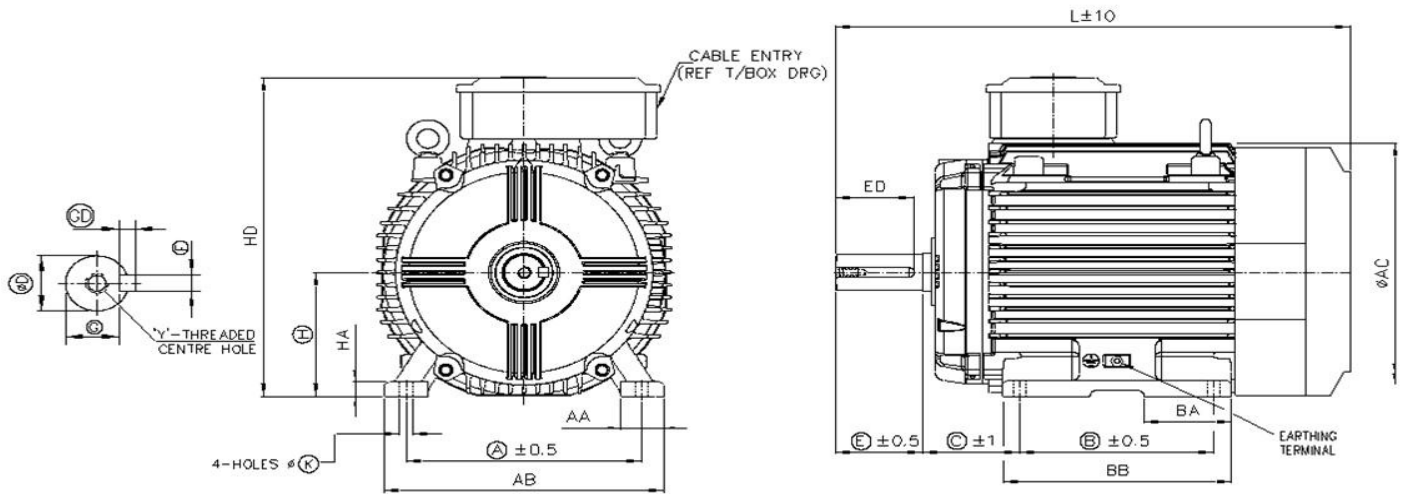

Frame	A	B	C	H	A A	AB	BA	BB	K	D	E	ED	F	GD	G	Y	A C	L	H D	H A
POLE : 2,4,6																				
PC80	125	100	50	80.0 79.7	35	158	--	127	10.0 10.5	19.009 18.996	40	32	6.00 5.97	6.0 5.97	15.5 15.3	M6X16	162	278	212	10
PC90S	140	100	56	90.0 89.7	35	175	--	186	10.0 10.5	24.009 23.996	50	40	8.00 7.96	7.0 6.9	20.0 19.8	M8X19	190	365	225	12
PC90L	140	125	56	90.0 89.7	35	175	--	186	10.0 10.5	24.009 23.996	50	40	8.00 7.96	7.0 6.9	20.0 19.8	M8X19	190	365	225	12
PC100L	160	140	63	100.0 99.7	34	195	--	206	12.0 12.5	28.009 27.996	60	50	8.00 7.96	7.0 6.9	24.0 23.8	M10X2 2	220	415	270	12
PC112M	190	140	70	112.0 111.7	40	230	68	194	12.0 12.5	28.009 27.996	60	50	8.00 7.96	7.0 6.9	24.0 23.8	M10X2 2	240	410	300	16
PC132S	216	140	89	132.0 131.7	40	256	80	210	12.0 12.5	38.018 38.002	80	70	10.00 9.964	8.0 7.9	33.0 32.8	M12X2 8	285	485	335	18
PC132M	216	178	89	132.0 131.7	40	256	80	210	12.0 12.5	38.018 38.002	80	70	10.00 9.964	8.0 7.9	33.0 32.8	M12X2 8	285	485	335	18
PC160M	254	210	108	160.0 159.5	60	314	100	298	15.0 15.5	42.018 42.002	110	80	12.00 11.957	8.0 7.9	37.0 36.8	M16X3 2	334	650	440	22
PC160L	254	254	108	160.0 159.5	60	314	100	298	15.0 15.5	42.018 42.002	110	80	12.00 11.957	8.0 7.9	37.0 36.8	M16X3 2	334	650	440	22
PC180L	279	279	121	180.0 179.5	65	344	96	324	15.0 15.5	48.018 48.002	110	80	14.00 13.957	9.0 8.9	42.5 42.3	M16X3 2	384	720	480	22
PC200L	318	305	133	200.0 199.5	70	388	100	356	19.0 19.5	55.030 55.011	110	80	16.00 15.957	10.0 9.91	49.0 48.8	M20X4 0	430	790	570	25
POLE : : 4,6																				
PC225S	356	286	149	225.0 224.5	70	426	109	374	19.5 19.0	60.030 60.011	140	110	18.00 17.957	11.0 10.91	53.0 52.8	M20X4 0	490	890	690	25
PC225M	356	311	149	225.0 224.5	70	426	109	374	19.5 19.0	60.030 60.011	140	110	18.0 17.957	11.0 10.91	53.0 52.8	M20X4 0	490	890	690	25
PC250S	406	311	168	250.0 249.5	78	484	135	420	24.5 24.0	65.030 65.011	140	110	18.0 17.957	11.0 10.91	58.0 57.5	M20X4 0	535	970	745	35
PC250M	406	349	168	250.0 249.5	78	484	135	420	24.5 24.0	65.030 65.011	140	110	18.0 17.957	11.0 10.91	58.0 57.5	M20X4 0	535	970	745	35
PC280S	457	368	190	280.0 279.0	85	545	164	488	24.5 24.0	75.030 75.011	140	110	20.00 19.948	12.00 11.91	67.5 67.3	M20X4 0	585	1085	810	35
PC280M	457	419	190	280.0 279.0	85	545	164	488	24.5 24.0	75.030 75.011	140	110	20.00 19.948	12.00 11.91	67.5 67.3	M20X4 0	585	1085	810	35

All dimensions are in mm

Some features may be different and may not be a part of standard

TEFC 3 PHASE FOOT MOUNTED TB ON TOP CAST IRON CONSTRUCTION MOTOR (IMB3)

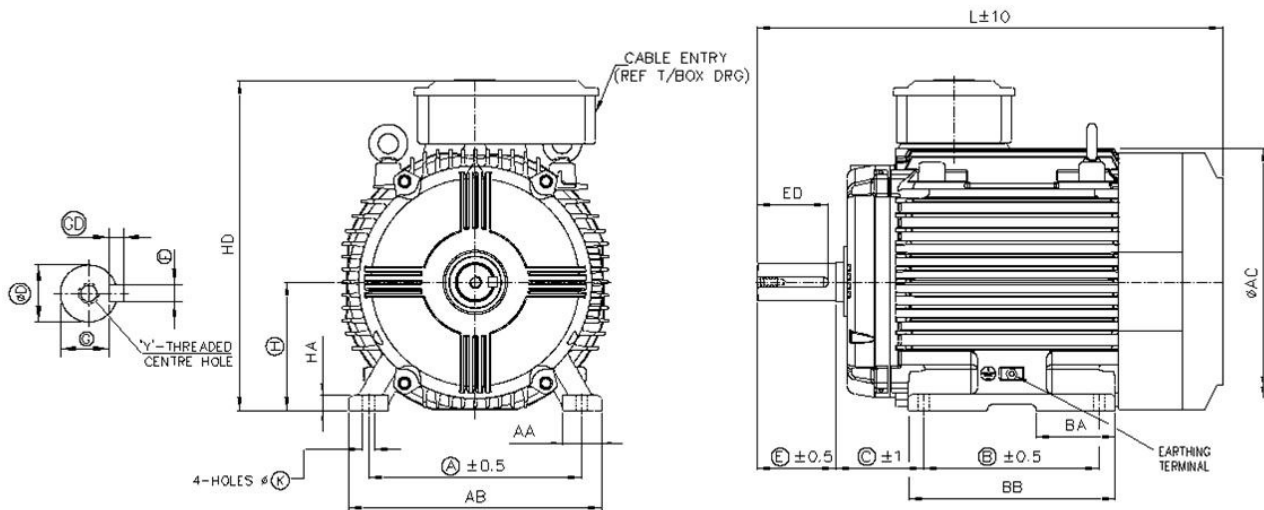

Frame	A	B	C	H	A A	AB	BA	BB	K	D	E	ED	F	GD	G	Y	A C	L	H D	H A
PC225S	356	286	149	225.0	70	426	109	374	19.5	55.030	110	80	16.00	10.0	49.0	M20X4	490	860	690	25
				224.5																
PC225M	356	311	149	225.0	70	426	109	374	19.5	55.030	110	80	16.00	10.0	49.0	M20X4	490	860	690	25
				224.5																
PC250S	406	311	168	250.0	78	484	135	420	24.5	60.030	140	110	18.00	11.0	53.0	M20X4	535	970	745	35
				249.5																
PC250M	406	349	168	250.0	78	484	135	420	24.5	60.030	140	110	18.00	11.0	53.0	M20X4	535	970	745	35
				249.5																
PC280S	457	368	190	280.0	85	545	164	488	24.5	65.030	140	110	18.00	11.0	58.0	M20X4	585	1085	810	35
				279.0																
PC280M	457	419	190	280.0	85	545	164	488	24.5	65.030	140	110	18.00	11.0	58.0	M20X4	585	1085	810	35
				279.0																

TEFC 3 PHASE FOOT MOUNTED TB ON SIDE CAST IRON CONSTRUCTION MOTOR

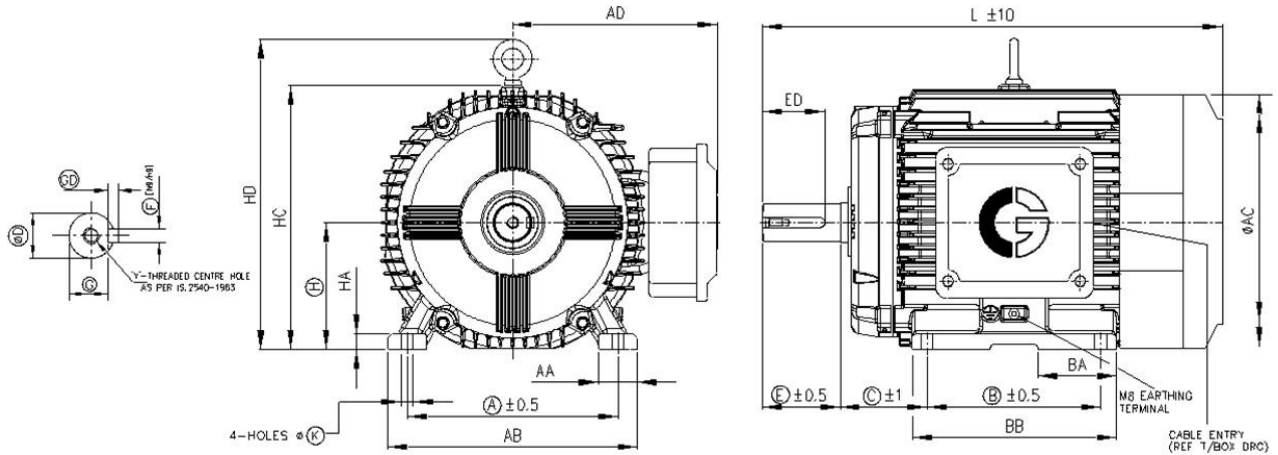

Frame	A	B	C	H	A A	AB	BA	BB	K	D	E	ED	F	GD	G	Y	A D	A C	L	H D	H A
-------	---	---	---	---	--------	----	----	----	---	---	---	----	---	----	---	---	--------	--------	---	--------	--------

POLE : 2,4,6

PC80	125	100	50	80.0 79.7	35	158	--	127	10.0 10.5	19.009 18.996	40	32	6.00 5.97	6.0 5.97	15.5 15.3	M6X16	127	162	278	160	10
PC90S	140	100	56	90.0 89.7	35	175	--	186	10.0 10.5	24.009 23.996	50	40	8.00 7.96	7.0 6.9	20.0 19.8	M8X19	135	190	365	232	12
PC90L	140	125	56	90.0 89.7	35	175	--	186	10.0 10.5	24.009 23.996	50	40	8.00 7.96	7.0 6.9	20.0 19.8	M8X19	135	190	365	232	12
PC100L	160	140	63	100.0 99.70	34	195	--	206	12.0 12.5	28.009 27.996	60	50	8.00 7.96	7.0 6.9	24.0 23.8	M10X2 2	170	220	415	262	12
PC112M	190	140	70	112.0 11.70	40	230	68	194	12.0 12.5	28.009 27.996	60	50	8.00 7.96	7.0 6.9	24.0 23.8	M10X2 2	180	240	410	285	16
PC132S	216	140	89	132.0 131.7	40	256	80	210	12.0 12.5	38.018 38.002	80	70	10.00 9.964	8.0 7.9	33.0 32.8	M12X2 8	200	285	485	320	18
PC132M	216	178	89	132.0 131.7	40	256	80	210	12.0 12.5	38.018 38.002	80	70	10.00 9.964	8.0 7.9	33.0 32.8	M12X2 8	200	285	485	320	18
PC160M	254	210	108	160.0 159.5	60	314	100	298	15.0 15.5	42.018 42.002	110	80	12.00 11.957	8.0 7.9	37.0 32.8	M16X3 2	280	334	650	380	22
PC160L	254	254	108	160.0 159.5	60	314	100	298	15.0 15.5	42.018 42.002	110	80	12.00 11.957	8.0 7.9	37.0 32.8	M16X3 2	280	334	650	380	22
PC180M	279	241	121	180.0 179.5	65	344	96	324	15.0 15.5	48.018 48.002	110	80	14.00 13.957	9.0 8.9	42.5 42.3	M16X3 2	305	384	720	430	22
PC180L	279	279	121	180.0 179.5	65	344	96	324	15.0 15.5	48.018 48.002	110	80	14.00 13.957	9.0 8.9	42.5 42.3	M16X3 2	305	384	720	430	22
PC200L	318	305	133	200.0 199.5	70	388	100	356	19.0 19.5	55.030 55.011	110	80	16.00 15.957	10.0 9.91	49.0 48.8	M20X4 0	440	440	790	485	25

POLE : 4,6

PC225S	356	286	149	225.0 224.5	70	426	109	374	19.5 19.0	60.030 60.011	140	110	18.00 17.957	11.0 10.91	53.0 52.8	M20X4 0	465	490	890	555	25
PC225M	356	311	149	225.0 224.5	70	426	109	374	19.5 19.0	60.030 60.011	140	110	18.00 17.957	11.0 10.91	53.0 52.8	M20X4 0	465	490	890	555	25
PC250S	406	311	168	250.0 249.5	78	484	135	420	24.5 24.0	65.030 65.011	140	110	18.00 17.957	11.0 10.91	58.0 57.8	M20X4 0	495	535	970	630	35
PC250M	406	349	168	250.0 249.5	78	484	135	420	24.5 24.0	65.030 65.011	140	110	18.00 17.957	11.0 10.91	58.0 57.8	M20X4 0	495	535	970	630	35
PC280S	457	368	190	280.0 279.0	85	545	164	488	24.5 24.0	75.030 75.011	140	110	20.00 19.948	12.00 11.91	67.5 67.3	M20X4 0	530	585	1085	690	35
PC280M	457	419	190	280.0 279.0	85	545	164	488	24.5 24.0	75.030 75.011	140	110	20.00 19.948	12.00 11.91	67.5 67.3	M20X4 0	530	585	1085	690	35

TEFC 3 PHASE FOOT MOUNTED TB ON SIDE CAST IRON CONSTRUCTION MOTOR

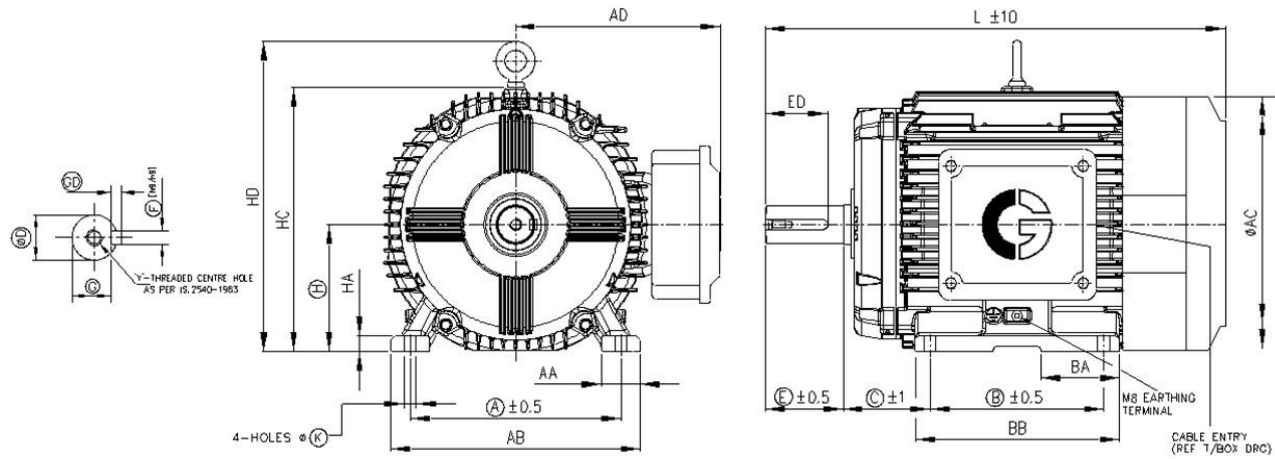

Frame	A	B	C	H	$\frac{A}{A}$	AB	BA	BB	K	D	E	ED	F	GD	G	Y	$\frac{A}{D}$	$\frac{A}{C}$	L	$\frac{H}{D}$	$\frac{H}{A}$
PC225S	356	286	149	225.0	70	426	109	374	19.5	55.030	110	80	16.00	10.0	49.0	M20X4	465	490	860	555	25
				224.5					19.0				15.957								
PC225M	356	311	149	225.0	70	426	109	374	19.5	55.030	110	80	16.00	10.0	49.0	M20X4	465	490	860	555	25
				224.5					19.0				15.957								
PC250S	406	311	168	250.0	78	484	135	420	24.5	60.030	140	110	18.00	11.0	53.0	M20X4	495	535	970	630	35
				249.5					24.0				17.957								
PC250M	406	349	168	250.0	78	484	135	420	24.5	60.030	140	110	18.00	11.0	53.0	M20X4	495	535	970	630	35
				249.5					24.0				17.957								
PC280S	457	368	190	280.0	85	545	164	488	24.5	65.030	140	110	18.00	11.0	58.0	M20X4	530	585	108	690	35
				279.0					24.0				17.957								
PC280M	457	419	190	280.0	85	545	164	488	24.5	65.030	140	110	18.00	11.0	58.0	M20X4	530	585	108	690	35
				279.0					24.0				17.957								

POLE : 2

TEFC 3 PHASE FLANGE MOUNTED CAST IRON CONSTRUCTION MOTOR (IMB5 / V1)

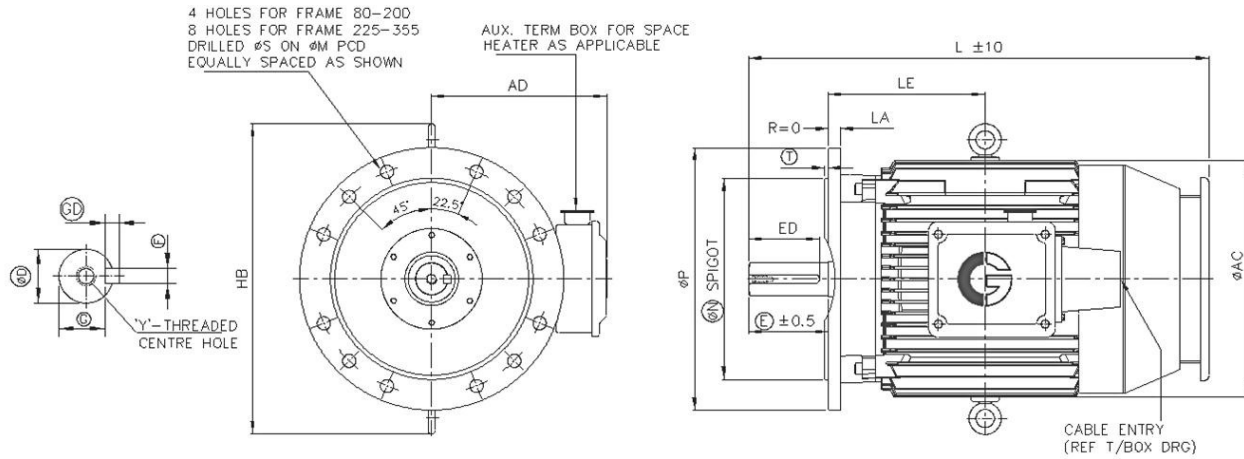

Frame	D	E	E D	F	GD	G	Y	AD	AC	L	M Tol	N Tol	P	S	T	LA	L E	HB
POLE : 2																		
PC80	19.009 18.996	40	32	6.00 5.97	6.0 5.97	15.5 15.3	M6X16	127	162	278	165.3 164.7	130.014 129.989	200	12	3.5	12	105	--
PC90S	24.009 23.996	50	40	8.00 7.96	7.0 6.9	20.0 19.8	M8X19	135	180	430	165.3 164.7	130.014 129.989	200	12	3.5	12	140	140
PC90L	24.009 23.996	50	40	8.00 7.96	7.0 6.9	20.0 19.8	M8X19	135	190	430	165.3 164.7	130.014 129.989	200	12	3.5	12	140	140
PC100L	28.009 27.996	60	50	8.00 7.96	7.0 6.9	24.0 23.8	M10X2 2	170	220	415	215.3 214.7	180.014 179.989	250	14.5	4	14.5	95	150
PC112M	28.009 27.996	60	50	8.00 7.96	7.0 6.9	24.0 23.8	M10X2 2	180	240	410	215.3 214.7	180.014 179.989	250	15	4	12	153	346
PC132S	38.018 38.002	80	70	10.00 9.964	8.0 7.9	33.0 32.8	M12X2 8	200	285	485	265.3 264.7	230.016 229.987	300	15	4	14	178	366
PC132M	38.018 38.002	80	70	10.00 9.964	8.0 7.9	33.0 32.8	M12X2 8	200	285	485	265.3 264.7	230.016 229.987	300	15	4	14	178	366
PC160M	42.018 42.002	110	80	12.00 11.957	8.0 7.9	37.0 36.8	M16X3 2	280	334	705	300.5 299.5	250.016 249.987	350	19	5	15	235	440
PC160L	42.018 42.002	110	80	12.00 11.957	8.0 7.9	37.0 36.8	M16X3 2	280	334	705	300.5 299.5	250.016 249.987	350	19	5	15	235	440
PC180M	48.018 48.002	110	80	14.00 13.957	9.0 8.9	42.5 42.3	M16X3 2	305	384	795	300.5 299.5	250.016 249.987	350	19	5	15	260	500
PC180L	48.018 48.002	110	80	14.00 13.957	9.0 8.9	42.5 42.3	M16X3 2	305	384	795	300.5 299.5	250.016 249.987	350	19	5	15	260	500
PC200L	55.030 55.011	110	80	16.00 15.957	10.0 9.91	49.0 48.8	M20X4 0	440	440	875	350.5 349.5	300.018 299.982	400	19	5	16	285	570
POLE : 4,6																		
PC225S	60.030 60.011	140	110	18.00 17.957	11.0 10.9 1	53.0 52.8	M20X4 0	465	490	975	400.5 399.5	350.018 349.982	450	19	5	18	305	550
PC225M	60.030 60.011	140	110	18.00 17.957	11.0 10.9 1	53.0 52.8	M20X4 0	465	490	975	400.5 399.5	350.018 349.982	450	19	5	18	305	550
PC250S	65.030 65.011	140	110	18.00 17.957	11.0 10.9 1	58.0 57.5	M20X4 0	495	535	1065	500.0 499.5	450.020 449.980	550	19	5	20	339	630
PC250M	65.030 65.011	140	110	18.00 17.957	11.0 10.9 1	58.0 57.5	M20X4 0	495	535	1065	500.0 499.5	450.020 449.980	550	19	5	20	339	630
PC280S	75.030 75.011	140	110	20.00 19.948	12.0 11.9 1	67.5 67.3	M20X4 0	530	585	1170	500.0 499.5	450.020 449.980	550	19	5	22	400	820
PC280M	75.030 75.011	140	110	20.00 19.948	12.0 11.9 1	67.5 67.3	M20X4 0	530	585	1170	500.0 499.5	450.020 449.980	550	19	5	22	400	820

All dimensions are in mm

TEFC 3 PHASE FLANGE MOUNTED CAST IRON CONSTRUCTION MOTOR (IMB5 / V1)

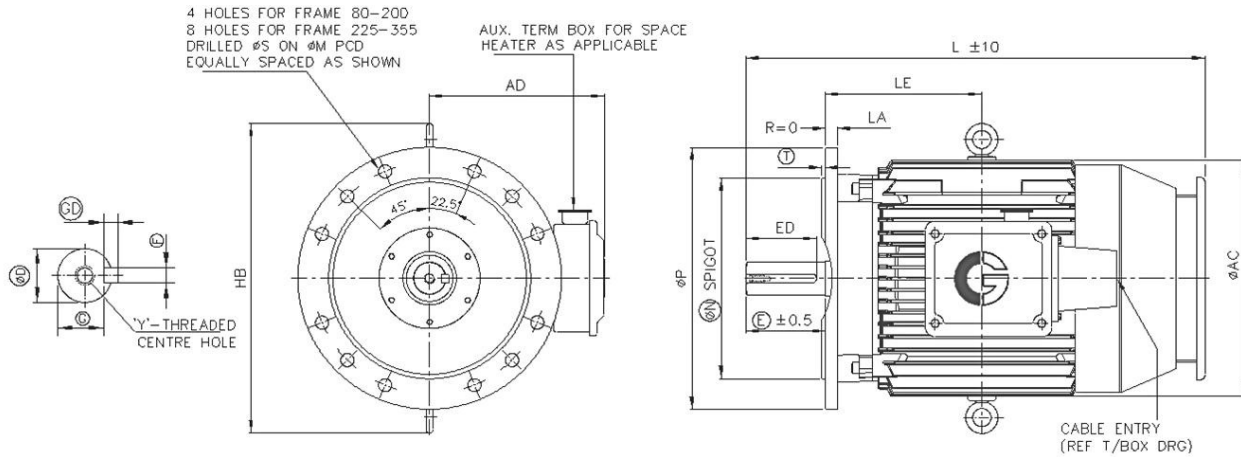

Frame	D	E	ED	F	GD	G	Y	AD	AC	L	M Tol	N Tol	P	S	T	LA	LE	HB
POLE : 2																		
PC225S	55.030 55.011	110	80	16.00 15.957	10.0 9.91	49.0 48.8	M20X 40	465	490	945	400.5 399.5	350.018 349.982	450	19	5	18	305	550
PC225M	55.030 55.011	110	80	16.00 15.957	10.0 9.91	49.0 48.8	M20X 40	465	490	945	400.5 399.5	350.018 349.982	450	19	5	18	305	550
PC250S	60.030 60.011	140	110	18.00 17.957	11.0 10.9 1	53.0 52.8	M20X 40	495	535	1065	500.0 499.5	450.020 449.980	550	19	5	20	339	630
PC250M	60.030 60.011	140	110	18.00 17.957	11.0 10.9 1	53.0 52.8	M20X 40	495	535	1065	500.0 499.5	450.020 449.980	550	19	5	20	339	630
PC280S	65.030 65.011	140	110	18.00 17.957	11.0 10.9 1	58.0 57.8	M20X 40	530	585	1170	500.0 499.5	450.020 449.980	550	19	5	22	400	820
PC280M	65.030 65.011	140	110	18.00 17.957	11.0 10.9 1	58.0 57.8	M20X 40	530	585	1170	500.0 499.5	450.020 449.980	550	19	5	22	400	820

PERFORMANCE DATA FOR APEX SERIES MOTOR

Efficiency values complying to IE3 class of IEC 60034-30:2008

PROD	RATED POWER		FRAME	FULL LOAD CURRENT (AMP)			FL	FLT	EFFICIENCY %			POWER FACTOR %			D.O.L STARTING		PULL-OUT	GD ²
	KW	HP		IN	SPEED	MN			FL	3/4L	1/2L	FL	3/4L	1/2L	STT %	SCC %		
CODE				380 V	400 V	415 V	RPM	kg-m										

2 POLE : 3000 RPM

0.75P2	0.75	1.00	PA/PC80M	1.60	1.52	1.47	2795	0.261	80.70	80.70	80.30	0.88	0.84	0.75	200	650	250	0.004
1.10P2	1.10	1.50	PA/PC80M	2.35	2.23	2.15	2845	0.376	82.70	82.70	82.00	0.86	0.82	0.72	225	700	275	0.005
1.50P2	1.50	2.00	PA/PC90S	3.15	2.99	2.88	2860	0.511	84.20	84.20	83.50	0.86	0.80	0.70	250	650	300	0.006
2.20P2	2.20	3.00	PA/PC90L	4.58	4.35	4.19	2850	0.751	85.90	85.90	85.50	0.85	0.80	0.70	275	700	325	0.008
3.00P2	3.00	4.00	PA/PC100L	5.88	5.59	5.38	2890	1.011	87.10	87.10	86.00	0.89	0.85	0.76	350	800	375	0.027
3.70P2	3.70	5.00	PA/PC100L	7.1	6.8	6.5	2870	1.255	87.80	87.80	88.10	0.90	0.87	0.80	250	700	300	0.032
4.00P2	4.00	5.50	PA/PC112M	7.7	7.3	7.0	2870	1.357	88.10	88.10	87.50	0.90	0.88	0.82	275	750	350	0.041
5.50P2	5.50	7.50	PA/PC132S	10.6	10.1	9.7	2880	1.859	89.20	89.20	88.50	0.88	0.84	0.78	150	650	200	0.093
7.50P2	7.50	10.00	PA/PC132S	14.4	13.7	13.2	2915	2.505	90.10	90.10	90.10	0.88	0.86	0.80	250	750	300	0.111
11P2	11.0	15.0	PC160M	21	20	19	2920	3.67	91.20	91.20	91.00	0.89	0.85	0.82	250	700	300	0.195
15P2	15.0	20.0	PC160M	28	26	25	2935	4.98	91.90	91.90	91.00	0.90	0.86	0.81	250	700	300	0.234
18.5P2	18.5	25.0	PC160L	34	32	31	2930	6.15	92.40	92.40	91.50	0.90	0.86	0.82	250	700	300	0.279
22P2	22.0	30.0	PC180M	40	38	37	2940	7.28	92.70	92.70	91.50	0.90	0.86	0.80	175	650	225	0.437
30P2	30.0	40.0	PC200L	53	50	49	2960	9.87	93.30	93.30	92.30	0.92	0.88	0.84	180	750	225	1.04
37P2	37.0	50.0	PC200L	65	62	60	2965	12.15	93.70	93.50	92.70	0.92	0.88	0.84	180	750	225	1.14
45P2	45.0	60.0	PC225M	79	75	72	2980	14.70	94.00	94.00	93.50	0.92	0.85	0.81	160	700	200	1.74
55P2	55.0	75.0	PC250M	96	92	88	2980	17.97	94.30	94.30	93.00	0.92	0.88	0.80	200	600	250	2.53
75P2	75.0	100.0	PC280S	134	127	122	2978	24.52	94.70	94.70	94.00	0.90	0.86	0.80	160	700	200	5.67
90P2	90.0	120.0	PC280M	156	149	143	2978	29.42	95.00	95.00	94.00	0.92	0.88	0.82	200	700	250	6.21

PA-Aluminum construction PC-Cast Iron construction

Tolerances are applicable as per IEC 60034-1 :2010

Full load currents indicted are given for respective design voltage

PERFORMANCE DATA FOR APEX SERIES MOTOR

Efficiency values complying to IE3 class of IEC 60034-30:2008

PROD CODE	RATED POWER		FRAME	FULL LOAD CURRENT (AMP)			FL SPEED RPM	FLT M _N kg-m	EFFICIENCY %			POWER FAC- TOR %			D.O.L STARTING		PULL- OUT POT %FLT	GD ² KG M ²
	KW	HP		380 V	400 V	415 V			FL	3/4L	1/2L	FL	3/4L	1/2L	STT % FLT	SCC % FLA		
0.75P4	0.75	1.00	PA/PC80M	1.89	1.80	1.73	1420	0.514	82.50	82.50	81.50	0.73	0.68	0.55	225	650	275	0.014
1.10P4	1.10	1.50	PA/PC90S	2.55	2.42	2.33	1420	0.754	84.10	84.00	82.40	0.78	0.71	0.58	200	600	250	0.015
1.50P4	1.50	2.00	PA/PC90L	3.82	3.63	3.49	1430	1.021	85.30	85.30	85.00	0.7	0.6	0.5	300	750	350	0.019
2.20P4	2.20	3.00	PA/PC100L	5.14	4.88	4.71	1445	1.482	86.70	86.70	86.00	0.75	0.7	0.6	225	650	275	0.053
3.00P4	3.00	4.00	PA/PC100L	7.22	6.86	6.61	1465	1.994	87.70	87.50	85.00	0.72	0.64	0.5	250	800	300	0.069
3.70P4	3.70	5.00	PA/PC112M	8.2	7.7	7.5	1455	2.476	88.40	88.40	88.00	0.78	0.75	0.65	225	750	275	0.086
4.00P4	4.00	5.50	PA/PC112M	8.6	8.1	7.9	1450	2.686	88.60	88.60	88.00	0.8	0.75	0.65	225	750	275	0.086
5.50P4	5.50	7.50	PA/PC132S	11.5	10.9	10.5	1460	3.667	89.60	89.60	89.00	0.81	0.76	0.66	250	650	300	0.200
7.50P4	7.50	10.00	PA/PC132M	16.2	15.4	14.8	1460	5.001	90.40	90.40	90.00	0.78	0.74	0.62	250	800	300	0.225
11P4	11.0	15.0	PC160M	22	21	20	1470	7.28	91.40	91.40	91.00	0.84	0.80	0.72	200	600	250	0.47
15P4	15.0	20.0	PC160L	29	28	27	1470	9.93	92.10	92.10	91.00	0.84	0.80	0.70	200	600	250	0.59
18.5P4	18.5	25.0	PC180M	36	34	33	1470	12.25	92.60	92.60	92.00	0.85	0.82	0.76	180	700	225	0.71
22P4	22.0	30.0	PC180L	44	42	41	1470	14.57	93.00	93.00	92.40	0.81	0.75	0.63	175	700	225	0.85
30P4	30.0	40.0	PC200L	57	54	52	1475	19.80	93.60	93.60	93.00	0.86	0.82	0.75	150	700	225	1.94
37P4	37.0	50.0	PC225S	70	66	64	1475	24.42	93.90	93.90	93.00	0.86	0.82	0.74	180	700	225	3.53
45P4	45.0	60.0	PC225M	84	80	77	1480	29.60	94.20	94.20	93.50	0.86	0.82	0.74	180	700	225	3.84
55P4	55.0	75.0	PC250M	100	95	92	1480	36.18	94.60	94.60	94.00	0.88	0.83	0.75	200	700	250	3.84
75P4	75.0	100.0	PC280S	136	129	125	1480	49.33	95.00	95.00	94.50	0.88	0.84	0.78	160	700	200	11.14
90P4	90.0	120.0	PC280M	161	153	148	1485	59.00	95.20	95.20	94.60	0.89	0.86	0.80	200	700	250	12.25

PA-Aluminum construction PC-Cast Iron construction

Tolerances are applicable as per IEC 60034-1 :2010

Full load currents indicated are given for respective design voltage

PERFORMANCE DATA FOR APEX SERIES MOTOR

Efficiency values complying to IE3 class of IEC 60034-30:2008

PROD CODE	RATED POWER		FRAME	FULL LOAD CURRENT (AMP)			FL SPEED RPM	FLT MN kg-m	EFFICIENCY %			POWER FAC-TOR %			D.O.L STARTING		PULL-OUT POT %FLT	GD ² KG M ²
	KW	HP		380 V	400 V	415 V			FL	3/4L	1/2L	FL	3/4L	1/2L	STT % FLT	SCC % FLA		
6 POLE : 1000 RPM																		
0.75P6	0.75	1.00	PA/PC90S	2.22	2.11	2.03	950	0.769	78.90	78.90	78.80	0.65	0.58	0.45	180	500	225	0.02
1.10P6	1.10	1.50	PA/PC90L	3.03	2.88	2.78	935	1.145	81.00	80.20	78.40	0.68	0.58	0.45	200	600	250	0.03
1.50P6	1.50	2.00	PA/PC100L	4.60	4.37	4.22	935	1.562	82.50	81.50	80.40	0.60	0.55	0.50	200	650	250	0.05
2.20P6	2.20	3.00	PA/PC112M	5.66	5.38	5.19	950	2.254	84.30	84.30	84.00	0.70	0.65	0.50	150	700	200	0.10
3.00P6	3.00	4.00	PA/PC132S	6.83	6.49	6.25	950	3.074	85.60	85.60	83.50	0.78	0.72	0.65	150	700	200	0.26
3.70P6	3.70	5.00	PA/PC132S	10.0	9.5	9.2	965	3.733	86.50	86.50	86.00	0.65	0.60	0.50	200	700	250	0.26
4.00P6	4.00	5.50	PA/PC132M	9.6	9.1	8.8	965	4.035	86.80	86.80	85.00	0.73	0.66	0.54	150	600	200	0.26
5.50P6	5.50	7.50	PA/PC132M	12.8	12.2	11.8	950	5.636	88.00	88.00	86.50	0.74	0.66	0.54	150	600	200	0.29
7.50P6	7.50	10.00	PC160M	17	16	15	970	7.53	89.10	89.10	89.10	0.77	0.70	0.60	180	500	225	0.43
11P6	11.0	15.0	PC160L	23	22	21	975	10.98	90.30	90.30	90.00	0.80	0.73	0.61	180	600	225	0.64
15P6	15.0	20.0	PC180L	30	29	28	978	14.93	91.20	91.20	91.00	0.82	0.77	0.67	175	650	250	1.26
18.5P6	18.5	25.0	PC200L	36	35	33	970	18.57	91.70	91.70	90.80	0.84	0.77	0.68	160	600	200	2.08
22P6	22.0	30.0	PC200L	43	41	39	970	22.08	92.20	92.20	91.00	0.85	0.78	0.68	150	600	200	2.33
30P6	30.0	40.0	PC225M	60	57	55	980	29.80	92.90	92.90	91.50	0.82	0.79	0.70	230	600	280	3.84
37P6	37.0	50.0	PC250M	73	69	66	985	36.57	93.30	93.30	92.80	0.83	0.79	0.70	200	600	250	5.56
46P6	45.0	60.0	PC280S	91	87	84	985	44.47	93.70	93.70	93.00	0.80	0.76	0.70	180	700	225	13.04
55P6	55.0	75.0	PC280M	111	105	102	985	54.36	94.10	94.10	93.80	0.80	0.76	0.70	200	700	250	14.42

PA-Aluminum construction PC-Cast Iron construction

Tolerances are applicable as per IEC 60034-1 :2010

Full load currents indicted are given for respective design voltage

Bearing details



Bearings			
FRAME	Pole	Driving End	Non-Driving End

Aluminum Motors

PA80	2,4,6	6204ZZ	6203ZZ
PA90	2,4,6	6205ZZ	6203ZZ
PA100	2,4,6	6206ZZ	6206ZZ
PA112	2,4,6	6206ZZ	6206ZZ
PA132	2,4,6	6208ZZ	6208ZZ

Cast Iron Motors

PC80	2,4,6	6204ZZ	6203ZZ
PC90	2,4,6	6205ZZ	6203ZZ
PC100	2,4,6	6206ZZ	6205ZZ
PC112	2,4,6	6206ZZ	6206ZZ
PC132	2,4,6	6208ZZ	6208ZZ
PC160	2,4,6	6309ZZ	6309ZZ
PC180	2,4,6	6310ZZ	6310ZZ
PC200	2,4,6	6312ZZ	6312ZZ
PC225	2,4,6	6313ZZ	6313ZZ
PC250	2,4,6	6314	6314
PC280	2	6314	6314
PC280	4,6	6318	6318

Shipping details

Shipping dimensions & weights			
FRAME	NET WT kg	GR WT kg	L X B X H (mm)

Aluminum Motors

PA80M	12	13	410 x 225 x 240
PA90S	16	17	420 x 270 x 230
PA90L	19	20	420 x 270 x 230
PA100L	28	30	500 x 300 x 350
PA112M	31	34	475 x 350 x 290
PA132S	54	56	540 x 450 x 330
PA132M	63	65	540 x 450 x 330

Cast Iron Motors

PC80M	17	21	410 x 225 x 240
PC90S	23	27	420 x 270 x 230
PC90L	28	32	420 x 270 x 230
PC100L	38	43	500 x 300 x 350
PC112M	43	56	485 x 410 x 340
PC132S	70	86	570 x 470 x 375
PC132M	78	94	570 x 470 x 375
PC160M	132	162	800 x 585 x 615
PC160L	152	182	800 x 585 x 615
PC180M	185	220	900 x 685 x 640
PC180L	197	232	900 x 685 x 640
PC200L	295	332	1000 x 775 x 665
PC225S	360	435	1075 x 825 x 750
PC225M	390	465	1075 x 825 x 750
PC250S	460	540	1150 x 950 x 875
PC250M	494	574	1150 x 950 x 875
PC280S	705	825	1580 x 1170 x
PC280M	760	880	1580 x 1170 x 1000

Note : Insulated bearing and roller bearings for frame 200 & above are available on request

Seven reasons to buy Apex Series IE3 Motors



- Lower life cycle cost
- Inverter compatible
- Low operating cost
- Tested as per IEC60034-2-1 in CSA approved test lab
- Lower Vibration levels, better than IEC standard
- Engineered to customer requirement
- Global support

North

Delhi : 3rd Floor, Express Building, 9,10 Bahadur Shah Jafar Marg, Near ITO Crossing, New Delhi – 110 002

Phone : +91 11 23460700

Lucknow : +91 522 3018850 / 59

Jalandhar : +91 181 2223801, 2459487

Jaipur : +91 141 2376919, 2376307

West

Mumbai : Kanjur Marg (E), Mumbai – 400 042

Phone : +91 22 67558632, 33, 36 & 67558000

Ahmadabad : +91 79 4001200, 40012201

Indore : +91 731 2498269, 2498276

Nagpur : +91 712 2531271, 2560870 / 71

Pune : +91 20 25534675 / 77

East

Kolkata: 50, Chowringhee Road, Kolkata – 700 071

Phone : +91 33 22829681 / 85

Bhubaneswar : +91 674 2531128 / 2531429

Patna : +91 612 2239405

Guwahati : +91 361 2543830, 255018

South

Chennai: 3 – A, MGR Salai (K. H. Road), Nungambakham,

Chennai – 600034

Phone : +91 44 4224 7525

Bengaluru : +91 80 41391931, 41391908 / 909

Secunderabad : +91 40 40002300, 40002347

Cochin : +91 484 2370860 / 63, 2360240

CG International division

Jagruti Buildings, 2nd Floor,

Kanjurmarg (E)

Mumbai, India.

Phone: +91 22 67558944

CG Power Solutions UK Limited,

Concepts House,3
 Watchgate , Newby Road
 Industrial Estate , Hazel
 Grove , SK7 5DB , United Kingdom
 T: + 44845 634 11 33

CG Drives & Automation

Polakkers 5
 55331 NX Bladel

 The Netherlands.
 Phone: +31 (0) 497 389 222

CG Sales Network

Americas Inc
 6349, AVANTHA Drive Inc

 Washington , Missouri

Industrial System— SEA Malaysia

B-1-21, Block B
 Jalan Sg. Jernih, 8/1,
 Pusat Perniagaan, Seksyen-8
 Petaling Jaya— 46050, Kualalumpur
 Malaysia

CG Drives & Automation

Mörsaregatan 12
 SE -250 24 Helsingborg, Sweden
 Phone : +46 42 169900
 Fax : +46 42 169949

CG Electric Systems Hungary Zrt.

Rotating Machine Business Unit ,
 H- 1095 Budapest,

 Mariassy Utca 7.
 Phone : + 36 14836600

CG Sales Network France S.A

Service Commercial -Paris ,

 41, Boulevard Vauban,
 78 280 GUYANCOURT,
 France.
 Phone: (+33) 01 34 52 10 80

PT. CG Power System, Indonesia

Global Sales Network
 Alamanda Buildings, 18th Floor
 JI TB simatupang kav 23-14,
 Jakarta 12430.
 Phone: +622 129660055
 Fax : +622 129660054

CG Drives & Automation

Goethestraße 6
 D- 38855 Wernigerode. Germany
 Phone : + 49 (0) 3943-92050
 Fax : + 49 (0) 3943-92055

CG Sales Network

Americas Inc
 3625 NW 82nd
 AVE; Ste 203, Miami, Florida.
 33166— USA

CG Sales Network UAE Ltd.

P. O. Box 5730
 Sharjah,
 UNITED ARAB EMIRATES
 Phone: + 971 6 574 03 13
 Fax : + 971 6 574 01 31

CG Drives & Automation

Rm 912 , Silver Centre
 1388 North Shanxi Road
 Putuo District
 Shanghai.
 China 200060
 Phone: +86 21 6149 8346