



Keeping Industry Turning

Series 10

Frame sizes 56 to 450

**BROOK
CROMPTON**
a **WOLONG** company

Introduction

2

Specification

Specification	Standard product	Option
Frame material	56- 160 aluminium 71 - 450 cast iron	- -
Enclosure	IP55	IP56, IP65
Mounting option	Foot (B3), Flange (B5), Face (B14)	Foot & Flange (B35), Foot & Face (B34)
Terminal box position	Top	-
Voltage	3 kW and below: 230 / 400 4 kW and above: 400 / 690	- -
Frequency	50 Hz	60 Hz
Cooling	IC411	-
Bearing location	56- 160 aluminium - non drive end 71 - 450 cast iron - non drive end	- -
Lubrication	56 - 160 double-shielded bearings 180 - 450 through greasing	- -
Insulation	class F	-
Temperature rise	class B	-
Paint colour	water blue (RAL 5021)	-
Heaters	-	110-120V or 220-240V
Thermal protection - IE2	80* -112 - Thermostats - aluminium 132 -160 - Thermistors - aluminium 71 - 450 - Thermistors - cast iron	- - -
Thermal protection - IE1	56 - 450 - Thermistors	-
Inverter Duty (with derate)	Variable Torque: 10:1 Constant Torque: 2:1	- -
Ambient temperature	-20°C to + 40°C	-

The above specification and options give a brief summary of features available for the Series 10 range.

For a full listing of optional features, please contact Brook Crompton sales.

* Thermistors on the 80 frame 0.55kW 4 pole

Brook Crompton Keeping Industry Turning

Brook Crompton, the original innovator in electric motor development, is a leading provider of energy efficient electric motors. With over 110 years' technical & design expertise, UK-based Brook Crompton delivers consistently reliable electric motors to a global market.

Trusted to power limitless industrial activities across diverse market sectors, the robust design of Brook Crompton's electric motors drives fans, pumps, compressors, conveyors and more, every second, of every day, of every year.

Driven by technology and innovation, Brook Crompton has one of the widest available ranges of electric motors for operation in hazardous atmospheres and hostile environments.

Renowned for their adaptability, Brook Crompton's extensive motor stock can be modified to suit the needs of different market sectors, with technical support from the company's knowledgeable team readily available to ensure the correct selection of motors for any application. For bespoke situations and complete flexibility, Brook Crompton will design and manufacture to meet individual customer specifications.

Brook Crompton has a long-standing reputation for efficient customer service, supporting customers worldwide through its global network. Specialist Brook Crompton Motor Centres operate alongside approved product distributors throughout the UK, mainland Europe, Middle East, Canada, USA, and Asia Pacific.

Shaping the future of electric motors, Brook Crompton is focused on the development of new products that improve energy efficiency, offer lower cost of ownership throughout the motor lifetime and reduce environmental impact.

Brook Crompton, the original innovator in electric motors.

Quality assurance

Stringent quality procedures are observed from first design to finished product in accordance with the ISO9001 quality systems.

All of our factories have been assessed to meet these requirements, a further assurance that only the highest standards of quality are accepted.

Series 10

The Brook Crompton Series 10 range is a high quality standard range of electric motors with a specification suitable for most industrial applications.

It covers outputs from 0.06kW up to 900kW in frame sizes 56 to 450.

Benefits include:

- Full output range to meet your requirements
- Efficiencies are within the IE1 & IE2 bands (where applicable).
- Robust construction for long life
- Mountings: foot, flange, face or combination
- Multi-mount - aluminium range
- Integrated feet cast iron - 71 to 450 frame.
- Euro voltage: up to 3kW 230/400V; 4kW and above 400/690V
- Dual frequency [50 / 60Hz]
- IP55
- Metal fan cover
- Metric entries
- Thermal protection fitted as standard
- Inverter duty

Standards and environment

Standards

Standards	
Series 10 motors are manufactured to the international standards listed below:	
Performance	IEC 60034-1
Dimensions	IEC 60072-1
Mounting	IEC 60034-7
Enclosure protection	IEC 60034-5
Vibration	IEC 60034-14 (grade A)
Noise	IEC60034-9

Environment Enclosure

All motors have degrees of IP protection as defined in IEC EN 60034-5. The normal arrangement is IP55. See Specification (page 2) for alternatives.

Motor cooling

Motors are cooled in accordance with IEC 60034-6. The normal arrangement is IC411 (Totally Enclosed Fan Ventilated) via a fan mounted at the non-drive end.

European directives

The following European directives apply:

Directives

Compliance with European directives applying to AC induction motors				
Directives	Low voltage (LV)	Machinery (MD)	Electromagnetic compatibility (EMC)	Energy related products (ErP)
Reference numbers	2014/35/EU [previously 73/23/EEC, 93/68/EEC & 2006/95/EC]	2006/42/EC [previously 89/392/EEC, 93/44/EEC, 98/37/EC & 98/79/EC]	2014/30/EU [previously 89/336/EEC, 92/31/EEC, 93/68/EEC & 2004/108/EC]	2009/125/EC [previously 92/42/EEC, 96/57/EC, 2000/55/EC & 2005/32/EC]
Motor CE marked	Yes	No	No	Yes
Standards	EN 60034	Not applicable	EN 60034-1	EN 60034-30
Documentation for customers' technical file	Declaration of conformity	Declaration of incorporation	Statement ⁽¹⁾	Declaration of conformity
Safety instructions with every motor	Yes	Yes	Yes	-
Comment	Relevant electrical equipment operating between 50 to 1000 volts AC	Statement ⁽²⁾	Component	Minimum efficiency levels for motor outputs 0.75 - 375kW 2-6 pole

⁽¹⁾ Motors operating from a correctly applied, sinusoidal (AC) supply meet the requirements of the EMC directive and are within the limits specified in standard EN 60034-1

⁽²⁾ When installed in accordance with our customer safety and installation and maintenance instructions, they can be put into service only when the machinery into which they are being incorporated, has been declared to be in conformity with the machinery directive in accordance with Article 4(2) and Annex IIB of that Directive [98/37/EEC]

Minimum Energy Performance Standard

The new standard

The EU MEPS scheme sets new **mandatory** minimum efficiency levels for most single speed 3ph induction motors up to 375kW rated up to 1000V, unlike the narrow definition of the CEMEP voluntary scheme which only covered a small number of standard motors.

The Voluntary Agreement, since 1998, of CEMEP for motor manufactures has expired (classes EFF3 /EFF2/EFF1).

The new standard for motors is now **mandatory** regulation in Europe.

The scope of EU MEPS covers 2, 4 & 6 pole single speed 3ph induction motors from 0.75 to 375kW, rated up to 1000V based on continuous duty operation.

Aiming to reduce energy consumption throughout Europe and the rest of the world, it comes into effect in 3 stages. The effect of this is to maximise potential savings in electric motor driven systems. Base of the regulation is a new international IEC 60034-30 standard. It defines the following efficiency classes:

- IE1 - Standard Efficiency (comparable to EFF2)
- IE2 - High Efficiency (comparable to EFF1 and USA EPACT 60 Hz)
- IE3 - Premium Efficiency (comparable to USA "NEMA Premium" 60 Hz)

New Efficiency levels in Europe (Time Line)

Mandatory from:

Since 1st January 2015:

Minimum efficiency requirement at IE3 level for 7.5 - 375kW motors or IE2 level for motors equipped with an appropriate variable speed drive. From 1st January 2017:

Minimum efficiency requirement at IE3 level for 0.75 - 375kW motors or IE2 level for motors equipped with an appropriate variable speed drive.

Performance data

4 3000 min⁻¹ (2 pole), aluminium construction

Rated power		Full load speed in revolutions per minute	Frame reference and size	Full load current at rated voltage			Efficiency	Power factor	Full load torque	Direct on line starting torque ratio	Direct on line pull up torque	Direct on line pull out torque	Direct on line starting current ratio	Rotor inertia Wkg	Mean Sound pressure level @ 1m on no load	Weight
P _N				I _N												
kW	hp	n min ⁻¹	Type	230 V A	400 V A	690 V A	η 1.0 P _N	cos φ 1.0 P _N	M _N Nm	$\frac{M_A}{M_N}$	$\frac{M_S}{M_N}$	$\frac{M_K}{M_N}$	$\frac{I_A}{I_N}$	J kgm ²	LPA dB(A)	kg
0.09	0.15	2750	B-DA56MA	0.52	0.30	-	62.0	0.70	0.31	2.1	-	2.2	5.2	0.00018	-	3.6
0.12	0.20	2750	B-DA56MB	0.62	0.36	-	67.0	0.72	0.41	2.1	-	2.2	5.2	0.00023	-	3.9
0.18	0.25	2720	B-DA63MA	0.87	0.50	-	65.0	0.80	0.63	2.2	-	2.3	5.5	0.00031	-	4.8
0.25	0.33	2720	B-DA63MB	1.14	0.66	-	68.0	0.81	0.88	2.2	-	2.3	5.5	0.0006	-	5.1
0.37	0.5	2740	B-DA71MA	1.62	0.94	-	70.0	0.81	1.28	2.2	-	2.3	6.1	0.00075	-	6.0
0.55	0.75	2740	B-DA71MB	2.30	1.33	-	73.0	0.82	1.91	2.2	-	2.3	6.1	0.0009	-	6.5
0.75	1.0	2870	A-DA80MA	2.93	1.69	-	77.4	0.83	2.49	2.5	-	3.0	5.3	0.0012	56	10.5
1.1	1.5	2870	A-DA80MB	4.18	2.40	-	79.6	0.83	3.66	3.2	-	3.8	7.0	0.0014	57	11.5
1.5	2.0	2890	A-DA90SA	5.45	3.13	-	81.3	0.85	4.96	2.7	-	3.5	7.1	0.0029	61	17.0
2.2	3.0	2890	A-DA90LA	7.81	4.49	-	83.2	0.85	7.27	2.4	-	3.0	6.9	0.0055	61	21.0
3.0	4.0	2890	A-DA100LA	10.2	5.88	-	84.6	0.87	9.91	3.2	-	4.0	8.0	0.0109	63	26.5
4.0	5.5	2900	A-DA112MA	-	7.65	4.43	85.8	0.88	13.2	2.5	-	3.0	7.5	0.0126	65	29.5
5.5	7.5	2930	A-DA132SA	-	10.4	6.01	87.0	0.88	17.9	2.7	-	3.5	7.5	0.0377	68	42.5
7.5	10	2930	A-DA132SB	-	14.0	8.09	88.1	0.88	24.4	2.4	-	3.3	7.5	0.0499	68	48.0
11.0	15	2940	A-DA160MA	-	20.0	11.6	89.4	0.89	35.7	2.2	-	2.9	7.6	0.055	72	88.0
15.0	20	2940	A-DA160MB	-	26.9	15.6	90.3	0.89	48.7	2.3	-	3.1	7.6	0.075	73	97.0
18.5	25	2940	A-DA160LA	-	33.0	19.1	90.9	0.89	60.1	2.3	-	3.1	7.4	0.124	73	107

A-DA frame nomenclature indicates an IE2 efficiency motor

Performance data

1500 min⁻¹ (4 pole), aluminium construction

Rated power		Full load speed in revolutions per minute	Frame reference and size	Full load current at rated voltage			Efficiency	Power factor	Full load torque	Direct on line starting torque ratio	Direct on line pull up torque	Direct on line pull out torque	Direct on line starting current ratio	Rotor inertia Wkg ²	Mean Sound pressure level @ 1m on no load	Weight
P _N				I _N												
kW	hp	n min ⁻¹	Type	230 V A	400 V A	690 V A	η 1.0 P _N	cos φ 1.0 P _N	M _N Nm	$\frac{M_A}{M_N}$	$\frac{M_S}{M_N}$	$\frac{M_K}{M_N}$	$\frac{I_A}{I_N}$	J kgm ²	L _{PA} dBA(A)	kg
0.06	0.08	1325	B-DA56MA	0.46	0.27	-	56.0	0.58	0.43	2.0	-	2.1	4.0	0.0003	-	3.6
0.09	0.12	1325	B-DA56MB	0.64	0.37	-	58.0	0.61	0.65	2.0	-	2.1	4.0	0.0004	-	3.9
0.12	0.16	1310	B-DA63MA	0.73	0.42	-	57.0	0.72	0.84	2.1	-	2.2	4.4	0.0005	-	4.8
0.18	0.25	1310	B-DA63MB	1.02	0.59	-	60.0	0.73	1.26	2.1	-	2.2	4.4	0.0006	-	5.1
0.25	0.33	1330	B-DA71MA	1.30	0.75	-	65.0	0.74	1.73	2.1	-	2.2	5.2	0.0008	-	6.0
0.37	0.50	1330	B-DA71MB	1.85	1.06	-	67.0	0.75	2.65	2.1	-	2.2	5.2	0.0013	-	6.3
0.55	0.75	1390	B-DA80MA	2.59	1.49	-	71.1	0.75	3.78	2.3	-	2.3	5.2	0.0018	-	12.5
0.75	1.0	1430	A-DA80MB	3.15	1.81	-	79.6	0.75	5.0	2.4	-	2.9	5.0	0.0021	46	14.0
1.1	1.5	1430	A-DA90SA	4.41	2.53	-	81.4	0.77	7.3	3.0	-	3.5	6.0	0.0023	48	18.0
1.5	2.0	1430	A-DA90LA	5.76	3.31	-	82.8	0.79	10.0	3.2	-	3.8	6.8	0.0027	48	20.5
2.2	3.0	1440	A-DA100LA	8.09	4.65	-	84.3	0.81	14.6	3.0	-	3.5	7.0	0.0054	52	29.0
3.0	4.0	1440	A-DA100LB	10.7	6.18	-	85.5	0.82	19.9	2.6	-	3.3	7.0	0.0067	52	34.0
4.0	5.5	1450	A-DA112MA	-	8.13	4.71	86.6	0.82	26.3	3.5	-	4.0	7.5	0.0095	53	38.0
5.5	7.5	1460	A-DA132SA	-	10.9	6.32	87.7	0.83	36.0	2.2	-	2.8	6.4	0.0214	59	48.0
7.5	10	1460	A-DA132MA	-	14.5	8.42	88.7	0.84	49.0	2.4	-	3.0	7.0	0.0296	59	58.5
11.0	15	1470	A-DA160MA	-	21.0	12.2	89.8	0.84	71.5	2.5	-	2.9	6.9	0.0747	62	90.0
15.0	20	1470	A-DA160LA	-	28.4	16.5	90.6	0.84	97.4	2.5	-	3.0	7.5	0.0918	62	104

A-DA frame nomenclature indicates an IE2 efficiency motor

Performance data

8

3000 min⁻¹ (2 pole), cast iron construction

P _N		n min ⁻¹	Type	I _N			h 1.0 P _N	Cos θ 1.0 P _N	M _N Nm	M _A M _N	M _S M _N	M _K M _N	I _A I _N	J kgm ²	L _{PA} dB(A)	kg
kW	hp			230 V A	400 V A	690 V A										
0.37	0.5	2740	B-DF71MA	1.63	0.94	-	70.0	0.81	1.29	2.2	-	2.2	6.1	0.0006	64	15.0
0.55	0.75	2740	B-DF71MB	2.30	1.33	-	73.0	0.82	1.88	2.2	-	2.3	6.1	0.0006	64	15.5
0.75	1.0	2870	A-DF80MA	2.93	1.69	-	77.4	0.83	2.50	2.5	-	3.0	5.3	0.0012	56	17.0
1.1	1.5	2870	A-DF80MB	4.18	2.40	-	79.6	0.83	3.66	3.2	-	3.8	7.0	0.0014	56	18.0
1.5	2.0	2870	A-DF90SA	5.45	3.13	-	81.3	0.85	4.96	2.7	-	3.5	7.1	0.0029	61	23.0
2.2	3.0	2890	A-DF90LA	7.81	4.49	-	83.2	0.85	7.27	2.4	-	3.0	6.9	0.0055	62	26.0
3.0	4.0	2890	A-DF100LA	10.2	5.88	-	84.6	0.87	9.91	3.2	-	4.0	8.0	0.0109	64	34.0
4.0	5.5	2900	A-DF112MA	-	7.65	4.43	85.8	0.88	13.2	2.5	-	3.0	7.5	0.0126	65	41.0
5.5	7.5	2930	A-DF132SA	-	10.4	6.01	87.0	0.88	17.9	2.7	-	3.5	7.5	0.0377	68	65.0
7.5	10	2930	A-DF132SB	-	14.0	8.09	88.1	0.88	24.4	2.4	-	3.3	7.5	0.0499	68	72.0
11.0	15	2940	A-DF160MA	-	20.0	11.6	89.4	0.89	35.7	2.2	-	2.9	7.6	0.055	73	112
15.0	20	2940	A-DF160MB	-	26.9	15.6	90.3	0.89	48.7	2.3	-	3.0	7.6	0.075	73	122
18.5	25	2940	A-DF160LA	-	33.0	19.1	90.9	0.89	60.1	2.3	-	3.1	7.4	0.124	73	136
22.0	30	2940	A-DF180MA	-	38.6	22.4	91.3	0.90	71.5	2.8	-	3.2	7.8	0.075	75	172
30.0	40	2960	A-DF200LA	-	52.3	30.3	92.0	0.90	96.8	2.6	-	3.0	7.8	0.124	78	223
37.0	50	2960	A-DF200LB	-	63.4	36.8	92.5	0.91	119.4	2.6	-	3.0	7.7	0.139	78	242
45.0	60	2960	AU-DF225M	-	77.7	45.0	92.9	0.90	145.2	2.4	-	2.6	7.5	0.233	78	326
55.0	75	2970	AU-DF250M	-	94.6	54.9	93.2	0.90	176.8	2.3	-	2.8	7.1	0.312	79	382
75.0	100	2970	AU-DF280S	-	127	73.5	93.8	0.91	241.2	2.5	-	2.8	7.4	0.579	80	525
90.0	125	2970	AU-DF280MA	-	152	87.9	94.1	0.91	289.4	2.8	-	2.8	7.6	0.675	80	570
110.0	150	2980	AU-DF315SA	-	185	107	94.3	0.91	352.5	2.4	-	2.8	6.9	1.18	82	930
132.0	175	2980	AU-DF315MA	-	219	127	94.6	0.92	423	2.6	-	2.9	7.1	1.82	82	990
160.0	215	2980	AU-DF315LA	-	268	155	94.8	0.91	512.8	2.5	-	2.9	7.1	2.08	85	1090
200.0	270	2980	AU-DF315LB	-	330	191	95.0	0.92	641	2.5	-	2.8	6.9	2.38	86	1120
250.0	335	2980	AU-DF355M	-	413	239	95.0	0.92	801.2	2.5	-	2.8	7.0	3.0	88	1900
315.0	430	2980	AU-DF355L	-	520	302	95.0	0.92	1009	2.5	-	2.9	7.0	3.5	89	2300
355.0	475	2975	AU-DF355LA	-	593	342	95.0	0.91	1140	1.23	-	2.53	5.8	12.52	-	2600
400.0	535	2975	BU-DF355LB	-	660	381	95.9	0.91	1284	1.64	-	2.03	7.11	13.26	-	3035
450.0	600	2975	BU-DF355LC	-	741	428	96.0	0.91	1444	1.47	-	2.72	6.42	14.21	-	3122
500.0	670	2982	BU-DF400LA	-	814	470	96.3	0.92	1601	1.20	-	2.90	6.14	20.07	-	3340
560.0	750	2982	BU-DF400LB	-	908	524	96.3	0.92	1793	0.98	-	2.57	5.46	20.07	-	3340
630.0	840	2982	BU-DF400LC	-	1019	589	96.3	0.93	2018	1.38	-	3.42	7.29	27.1	-	4020
710.0	950	2988	BU-DF450LA	-	1138	657	96.6	0.94	2269	1.20	-	2.00	7.00	27.6	-	4200
800.0	1080	2986	BU-DF450LB	-	1276	737	96.7	0.94	2559	1.20	-	2.00	7.00	28.1	-	4400
900.0	1200	2985	BU-DF450LC	-	1435	829	96.7	0.94	2879	1.20	-	2.00	7.00	28.1	-	4650

A/AU-DF frame nomenclature indicates an IE2 efficiency motor

Performance data

1500 min⁻¹ (4 pole), cast iron construction

Rated power		Full load speed in revolutions per minute	Frame reference and size	Full load current at rated voltage			Efficiency	Power factor	Full load torque	Direct on line starting torque ratio	Direct on line pull up torque	Direct on line pull out torque	Direct on line starting current ratio	Rotor inertia Wc	Mean sound pressure level (g 1m on no load)	Weight
P _N				I _N												
kW	hp	n	Type	230 V A	400 V A	690 V A	η	cos φ	M _N	M _A	M _S	M _K	I _A	J	L _{PA}	kg
		min ⁻¹					1.0 P _N	1.0 P _N	Nm	M _N	M _N	M _N	I _N	kgm ²	dB(A)	
0.25	0.33	1330	B-DF71MA	1.30	0.75	-	65.0	0.74	1.80	2.1	-	2.2	5.2	0.0006	55	14.0
0.37	0.50	1330	B-DF71MB	1.83	1.06	-	67.0	0.75	2.66	2.1	-	2.2	5.2	0.0008	55	14.5
0.55	0.75	1390	B-DF80MA	2.58	1.49	-	71.1	0.75	3.78	2.2	-	2.3	5.2	0.0018	58	15.0
0.75	1.0	1430	A-DF80MB	3.15	1.81	-	79.6	0.75	5.01	2.4	-	2.9	5.0	0.0021	46	16.0
1.1	1.5	1430	A-DF90SA	4.41	2.53	-	81.4	0.77	7.35	3.0	-	3.5	6.0	0.0023	48	23.0
1.5	2.0	1430	A-DF90LA	5.76	3.31	-	82.8	0.79	10.0	3.2	-	3.8	6.8	0.0027	48	25.0
2.2	3.0	1440	A-DF100LA	8.09	4.65	-	84.3	0.81	14.6	3.0	-	3.5	7.0	0.0054	52	33.0
3.0	4.0	1440	A-DF100LB	10.7	6.18	-	85.5	0.82	19.9	2.6	-	3.3	7.0	0.0067	52	34.0
4.0	5.5	1410	A-DF112MA	13.3	8.13	4.71	86.6	0.82	26.3	3.5	-	4.0	7.5	0.0095	53	38.0
5.5	7.5	1460	A-DF132SA	-	10.9	6.32	87.7	0.83	40.0	2.2	-	2.8	6.4	0.0214	59	65.0
7.5	10	1460	A-DF132MA	-	14.5	8.42	88.7	0.84	49.0	2.4	-	3.0	7.0	0.0296	59	76.0
11.0	15	1470	A-DF160MA	-	21.0	12.2	89.8	0.84	71.4	2.5	-	2.9	6.9	0.0747	62	118
15.0	20	1470	A-DF160LA	-	28.4	16.5	90.6	0.84	97.4	2.5	-	3.0	7.5	0.0918	62	132
18.5	25	1470	A-DF180MA	-	34.0	19.7	91.2	0.86	120.2	2.6	-	3.1	7.8	0.139	64	164
22.0	30	1470	A-DF180LA	-	39.8	23.1	91.6	0.87	143	2.6	-	3.1	7.5	0.158	64	182
30.0	40	1470	A-DF200L	-	53.9	31.3	92.3	0.87	195	2.4	-	2.9	7.1	0.262	64	245
37.0	50	1480	A-DF255S	-	66.2	38.4	92.7	0.87	239	2.5	-	2.7	7.5	0.406	64	258
45.0	60	1475	AU-DF225M	-	80.2	46.5	93.1	0.87	290.4	2.5	-	2.8	7.6	0.469	65	290
55.0	75	1475	AU-DF250MA	-	97.6	56.6	93.5	0.87	356	2.6	-	2.7	7.3	0.66	66	388
75.0	100	1480	AU-DF280S	-	132	76.7	94.0	0.87	484	2.7	-	2.7	7.6	1.12	69	510
90.0	125	1480	AU-DF280MA	-	159	91.9	94.2	0.87	581	2.7	-	2.7	7.5	1.46	69	606
110.0	150	1485	AU-DF315S	-	189	109	94.5	0.89	707	2.7	-	2.9	7.1	3.11	77	910
132.0	175	1485	AU-DF315M	-	226	131	94.7	0.89	849	2.7	-	2.9	7.3	3.62	77	1000
160.0	215	1485	AU-DF315LA	-	273	159	94.9	0.89	1029	3.0	-	3.0	7.4	4.13	82	1055
200.0	270	1485	AU-DF315LB	-	341	198	95.1	0.89	1286	3.0	-	3.0	7.6	4.73	82	1128
250.0	335	1485	AU-DF355M	-	422	244	95.1	0.90	1608	2.8	-	2.9	7.5	6.5	84	1700
315.0	430	1490	AU-DF355L	-	531	308	95.1	0.90	2026	2.6	-	2.8	7.4	8.2	84	1900
355.0	475	1485	AU-DF355LA	-	612	353	95.1	0.88	2283	1.93	-	2.6	6.5	9.5	-	2150
400.0	535	1485	BU-DF355LB	-	680	393	96.4	0.88	2572	1.80	-	2.6	6.5	10.6	-	2300
450.0	600	1485	BU-DF355LC	-	757	437	96.4	0.89	2894	1.80	-	2.6	6.5	11.5	-	2460
500.0	670	1492	BU-DF400LA	-	831	480	96.4	0.90	3200	1.83	-	2.52	6.19	18.41	-	3132
560.0	750	1492	BU-DF400LB	-	924	533	96.4	0.90	3585	2.02	-	2.67	6.64	19.62	-	3548
630.0	840	1492	BU-DF400LC	-	1043	602	96.4	0.91	4033	1.75	-	2.34	5.81	21.33	-	3589
710.0	950	1492	BU-DF450LA	-	1164	672	96.4	0.91	4545	1.30	-	2.57	6.17	41.00	-	4055
800.0	1070	1492	BU-DF450LB	-	1308	755	96.6	0.93	5120	1.53	-	2.28	6.91	49.50	-	4724
900.0	1200	1492	BU-DF450LC	-	1496	864	96.6	0.92	5760	1.75	-	2.34	5.81	49.50	-	4732

A/AU-DF frame nomenclature indicates an IE2 efficiency motor

Performance data

10

1000 min⁻¹ (6 pole), cast iron construction

Rated power
Full load speed in revolutions per minute
Frame reference and size
Full load current at rated voltage
Efficiency
Power factor
Full load torque
Direct on line starting torque ratio
Direct on line pull up torque
Direct on line pull out torque
Direct on line starting current ratio
Rotor inertia WKr
Mean Sound pressure level @ 1m on no load
Weight

P _N		n min ⁻¹	Type	I _N			h 1.0 P _N	Cos θ 1.0 P _N	M _N Nm	M _A M _N	M _S M _N	M _K M _N	I _A I _N	J kgm ²	L _{PA} dB(A)	kg
kW	hp			230 V A	400 V A	690 V A										
0.18	0.25	850	B-DF71MA	1.21	0.70	-	56.0	0.66	2.02	1.9	-	2.0	4.4	0.0011	52	14.0
0.25	0.33	850	B-DF71MB	1.56	0.90	-	59.0	0.68	2.81	1.9	-	2.0	4.0	0.0014	52	14.5
0.37	0.5	885	B-DF80MA	2.13	1.23	-	62.0	0.70	3.99	1.9	-	2.0	4.7	0.0016	54	15.0
0.55	0.75	885	B-DF80MB	2.94	1.70	-	65.0	0.72	5.94	1.9	-	2.1	4.7	0.0019	54	16.0
0.75	1.0	920	A-DF90SA	3.45	1.98	-	75.9	0.72	7.79	2.2	-	2.4	4.5	0.0029	45	19.0
1.1	1.5	920	A-DF90LA	4.84	2.78	-	78.1	0.73	11.4	2.4	-	2.6	4.5	0.0035	45	22.0
1.5	2.0	940	A-DF100LA	6.29	3.62	-	79.8	0.75	15.2	1.8	-	2.2	4.2	0.0069	49	32.0
2.2	3.0	960	A-DF112MA	8.88	5.11	-	81.8	0.76	21.9	2.3	-	2.8	4.5	0.014	53	41.0
3.0	4.0	960	A-DF132SA	11.9	6.84	-	83.3	0.76	29.8	1.8	-	2.4	4.5	0.0286	53	44.0
4.0	5.5	960	A-DF132MA	-	8.98	5.21	84.6	0.76	39.8	2.3	-	2.7	5.0	0.0357	55	53.0
5.5	7.5	960	A-DF132MB	-	12.0	6.95	86.0	0.77	54.7	1.9	-	2.8	5.5	0.0449	55	63.5
7.5	10	970	A-DF160MA	-	15.9	9.23	87.2	0.78	73.8	2.0	-	3.0	6.5	0.081	57	118
11.0	15	970	A-DF160LA	-	22.7	13.1	88.7	0.79	108.3	2.4	-	3.3	7.5	0.116	57	145
15.0	20	970	A-DF180LA	-	29.4	17.1	89.7	0.82	147.7	2.0	-	2.7	6.4	0.207	58	198
18.5	25	970	A-DF200LA	-	36.5	21.1	90.4	0.81	182.1	2.3	-	3.0	7.0	0.315	58	200
22.0	30	970	A-DF200LB	-	43.1	25.0	90.9	0.81	216.6	2.3	-	2.8	7.0	0.36	61	228
30.0	40	980	AU-DF225M	-	56.2	32.6	91.7	0.84	292.3	2.2	-	2.7	6.5	0.547	62	265
37.0	50	985	AU-DF250M	-	68.1	39.5	92.2	0.85	358.7	2.5	-	2.7	6.9	0.843	62	370
45.0	60	980	AU-DF280S	-	81.5	47.2	92.7	0.86	438.5	2.2	-	2.4	7.0	1.39	63	490
55.0	75	980	AU-DF280MA	-	99.2	57.5	93.1	0.86	536	2.4	-	2.5	7.1	1.65	64	540
75.0	100	990	AU-DF315SA	-	134	77.9	93.7	0.86	723	2.8	-	3.0	7.3	4.11	68	900
90.0	125	990	AU-DF315MA	-	161	93.2	94.0	0.86	868	2.7	-	2.9	7.1	4.78	68	980
110.0	150	990	AU-DF315LA	-	196	113	94.3	0.86	1061	2.9	-	2.9	7.4	5.45	73	1045
132.0	175	990	AU-DF315LB	-	231	133	94.6	0.87	1273	3.0	-	3.1	7.6	6.12	73	1100
160.0	215	990	AU-DF355MA	-	277	160	94.8	0.88	1543	3.1	-	3.1	7.6	9.5	80	1550
200.0	270	990	AU-DF355MB	-	345	200	95.0	0.88	1929	3.0	-	3.0	7.8	10.4	80	1600
250.0	335	990	AU-DF355L	-	432	249	95.0	0.88	2412	3.1	-	3.0	7.7	12.4	80	1700
315.0	420	990	AU-DA355LA	-	563	325	95.0	0.85	3039	2.1	-	2.4	6.5	13.5	-	2310
355.0	480	990	AU-DF355LB	-	634	366	95.0	0.85	3424	2.1	-	2.4	6.5	14.3	-	2490
400.0	544	990	BU-DF400LA	-	701	405	95.9	0.86	3856	2.08	-	2.48	6.38	21.86	-	3560
450.0	612	994	BU-DF400LB	-	783	452	95.9	0.86	4323	2.07	-	2.43	6.31	22.31	-	3840
500.0	680	994	BU-DF400LC	-	871	503	96.1	0.86	4804	1.86	-	2.19	5.72	23.52	-	3870
560.0	760	994	BU-DF450MB	-	874	505	96.0	0.86	5380	1.64	-	2.32	5.99	54.10	-	4200
630.0	850	994	BU-DF450LA	-	1097	633	96.1	0.86	6052	1.65	-	2.30	5.99	60.60	-	4620
710.0	960	994	BU-DF450LB	-	1235	713	95.9	0.86	6821	1.71	-	2.33	6.13	67.90	-	5080
800.0	1080	994	BU-DF450LC	-	1381	797	96.5	0.87	7686	1.52	-	2.06	5.47	67.90	-	5080

A/AU-DF frame nomenclature indicates an IE2 efficiency motor

Performance data notes

750 min⁻¹ (8 pole), cast iron construction

Rated power		Full load speed in revolutions per minute	Frame reference and size	Full load current at rated voltage			Efficiency	Power factor	Full load torque	Direct on line starting torque ratio	Direct on line pull up torque	Direct on line pull out torque	Direct on line starting current ratio	Rotor inertia Wk ²	Mean sound pressure level (g 1m on no load)	Weight
P _N kW	hp			I _N 230 V A	400 V A	690 V A										
n min ⁻¹	Type	h 1.0 P _N	Cos φ 1.0 P _N	M _N Nm	M _A M _N	M _S M _N	M _K M _N	I _A I _N	J kgm ²	L _{PA} dB(A)	kg					
0.09	0.15	600	B-DF71MA	0.99	0.57	-	40.0	0.57	1.3	1.8	-	1.9	2.8	0.0008	48	6.0
0.12	0.20	600	B-DF71MB	1.21	0.70	-	45.0	0.57	2.16	1.8	-	1.9	2.8	0.0010	48	6.3
0.18	0.25	645	B-DF80MA	1.45	0.84	-	51.0	0.61	2.66	1.8	-	1.9	3.3	0.0025	48	8.9
0.25	0.33	645	B-DF80MB	1.90	1.10	-	54.0	0.61	3.70	1.8	-	1.9	3.3	0.0030	48	10.4
0.37	0.5	670	B-DF90S	2.44	1.41	-	62.0	0.61	5.27	1.8	-	1.9	4.9	0.0051	53	12.1
0.55	0.75	670	B-DF90LA	3.58	2.07	-	63.0	0.61	7.84	1.8	-	2.0	4.0	0.0065	53	13.7
0.75	1.0	680	B-DF100LA	3.95	2.28	-	71.0	0.67	10.5	1.8	-	2.0	4.0	0.0095	56	23.0
1.1	1.5	680	B-DF100LB	5.45	3.15	-	73.0	0.69	15.4	1.8	-	2.0	5.0	0.0110	56	25.1
1.5	2.0	690	B-DF112MA	7.24	4.18	-	75.0	0.69	20.8	1.8	-	2.0	5.0	0.0245	59	28.2
2.2	3.0	705	B-DF132S	9.92	5.73	-	78.0	0.71	29.8	1.8	-	2.0	6.0	0.0314	61	40.3
3.0	4.0	705	B-DF132M	13.0	7.51	-	79.0	0.73	40.6	1.8	-	2.0	6.0	0.0395	61	45.0
4.0	5.5	720	B-DF160MA	-	9.76	5.64	81.0	0.73	53.1	1.9	-	2.0	6.0	0.0753	65	68.5
5.5	7.5	720	B-DF160MB	-	12.9	7.44	83.0	0.74	72.9	2.0	-	2.0	6.0	0.0931	65	76.0
7.5	10	720	B-DF160L	-	16.9	9.76	85.5	0.75	99.5	2.0	-	2.0	6.0	0.1260	65	86.2
11.0	15	730	B-DF180L	-	23.9	13.8	87.5	0.76	144	2.0	-	2.0	6.0	0.203	70	160
15.0	20	730	B-DF200L	-	32.4	18.7	88.0	0.76	196	2.0	-	2.0	6.6	0.399	73	228
18.5	25	730	BU-DF225S	-	39.0	22.5	90.0	0.76	242	1.9	-	2.0	6.6	0.491	73	242
22.0	30	730	BU-DF225M	-	45.0	26.0	90.5	0.78	288	1.9	-	2.0	6.6	0.547	73	265
30.0	40	735	BU-DF250M	-	60.2	34.8	91.0	0.79	390	1.9	-	2.0	6.6	0.834	75	368
37.0	50	735	BU-DF280S	-	73.9	42.7	91.5	0.79	481	1.9	-	2.0	6.6	1.93	76	472
45.0	60	735	BU-DF280M	-	89.4	51.6	92.0	0.79	585	1.8	-	2.0	6.6	3.65	76	538
55.0	75	735	BU-DF315SA	-	106	61.2	92.8	0.81	715	1.8	-	2.0	6.6	4.79	82	900
75.0	100	735	BU-DF315MA	-	144	83.1	93.0	0.81	975	1.8	-	2.0	6.6	5.58	82	1000
90.0	125	735	BU-DF315LA	-	169	97.6	93.8	0.82	1169	1.8	-	2.0	6.6	6.37	82	1055
110.0	150	735	BU-DF315LB	-	206	119	94.0	0.82	1429	1.8	-	2.0	6.4	7.23	82	1118
132.0	175	740	BU-DF355MA	-	248	143	93.7	0.82	1704	1.8	-	2.0	6.4	7.9	90	2000
160.0	215	740	BU-DF355MB	-	299	172	94.2	0.82	2065	1.8	-	2.0	6.4	10.3	90	2150
200.0	270	740	BU-DF355L	-	368	212	94.5	0.83	2581	1.8	-	2.0	6.4	12.3	90	2250
250.0	340	740	BU-DF355LB	-	485	280	95.3	0.78	3226	1.80	-	2.0	6.5	14.53	-	2460
315.0	420	740	BU-DF355LC	-	610	352	95.5	0.78	4065	1.80	-	2.0	6.5	15.39	-	2750
355.0	480	745	BU-DF400LB	-	641	370	95.6	0.85	4551	1.72	-	2.25	5.84	29.76	-	3592
400.0	540	745	BU-DF400LC	-	723	417	95.6	0.85	5128	1.96	-	2.44	6.39	31.34	-	3949
450.0	600	745	BU-DF450LB	-	817	472	95.7	0.83	5768	1.62	-	2.18	5.43	75.20	-	4660
500.0	675	745	BU-DF450LC	-	913	527	95.7	0.83	6409	1.74	-	2.23	5.65	79.30	-	4870

Dimensions

12 Foot, flange and face mounting - frame sizes 80 to 160 aluminium (A-DA)

IM B3
IM 1001
Mounting options

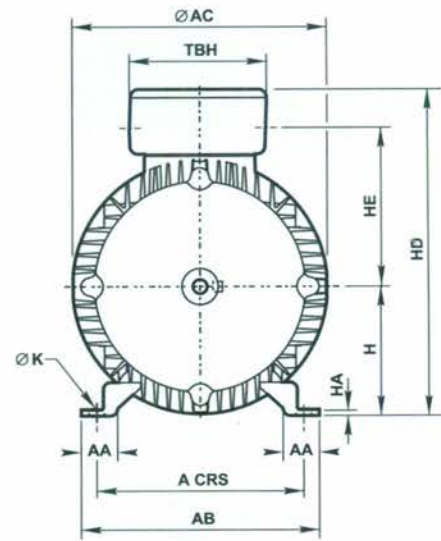
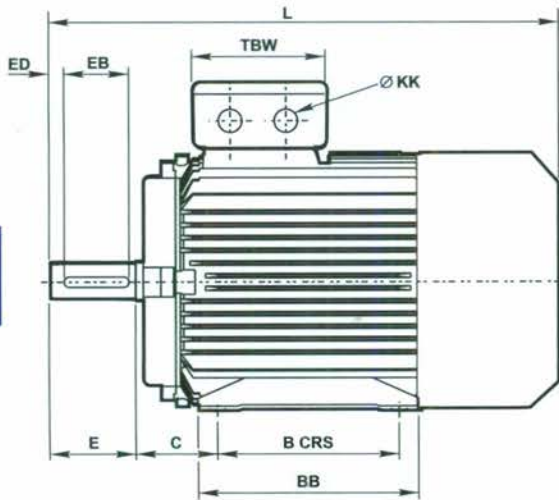

IM B5/IM B35
IM 3001/IM 2001
Mounting options

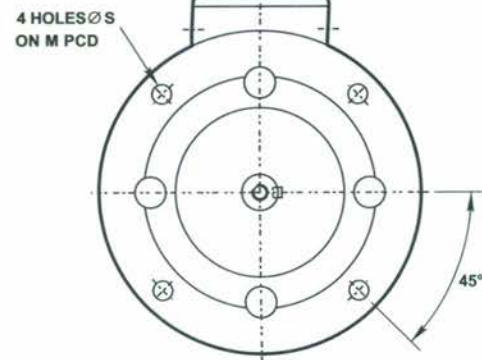
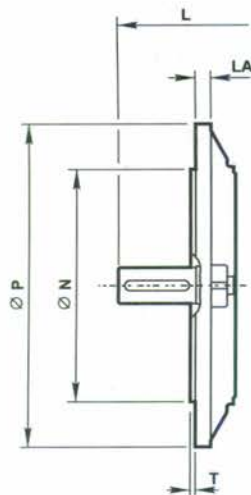

IM B14/IM B34
IM 3601/IM 2101
Mounting options

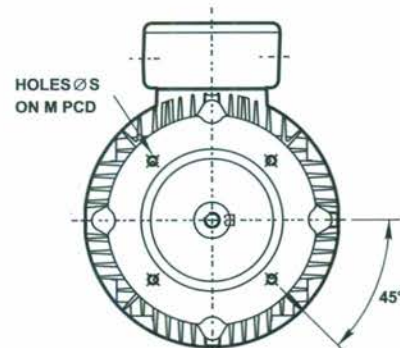
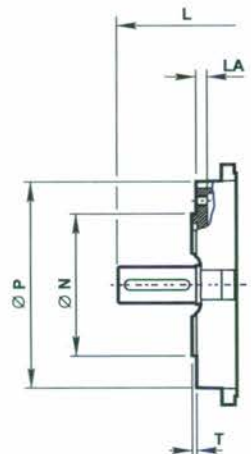

Dimensions

Foot, flange and face mounting - frame sizes 80 to 160 aluminium (A-DA)

General														Terminal box		
Type	A	B	C	H	K	L	AA	AB	AC	BB	HA	HD	HE	TBW	TBH	KK
A-DA80M	125	100	50	80	10 x 14	290	35	157	158	125	8	213	104	101	101	1 x M25
A-DA90S	140	100	56	90	10 x 14	325	37	173	175	125	10	233	112	109	109	1 x M25
A-DA90L	140	125	56	90	10 x 14	350	37	173	175	150	10	233	112	109	109	1 x M25
A-DA100L	160	140	63	100	12 x 16	398	40	196	198	172	11	260	124	109	109	1 x M32
A-DA112M	190	140	70	112	12 x 16	440	41	227	219	180	12	281	135	119	119	2 x M32
A-DA132S	216	140	89	132	12 x 16	475	51	262	258	186	15	320	153.5	119	119	2 x M32
A-DA132M	216	178	89	132	12 x 16	513	51	262	258	224	15	320	153.5	119	119	2 x M32
A-DA160M	254	210	108	160	15 x 18	609	55	309	315	260	18	402	194.5	155	164	2 x M40
A-DA160L	254	254	108	160	15 x 18	653	55	309	315	304	18	402	194.5	155	164	2 x M40

Flange & Face													
Type	IM B5 mounting						IM B14 mounting						
	M	N	P	S	T	LA	M	N	P	S	T	LA	
A-DA80M	165	130	200	12	3.5	12	100	80	120	M6	3.0	-	
A-DA90S	165	130	200	12	3.5	11	115	95	140	M8	3.0	14	
A-DA90L	165	130	200	12	3.5	11	115	95	140	M6	3.0	14	
A-DA100L	215	180	250	14.5	4.0	13	130	110	160	M8	3.5	15	
A-DA112M	215	180	250	14.5	4.0	14	130	110	160	M8	3.5	15	
A-DA132S	265	230	300	14.5	4.0	14	165	130	200	M10	3.5	17	
A-DA132M	265	230	300	14.5	4.0	14	165	130	200	M10	3.5	17	
A-DA160M	300	250	350	18.5	5.0	15	215	180	250	M12	4	-	
A-DA160L	300	250	350	18.5	5.0	15	215	180	250	M12	4	-	

Shaft									
Type	D	E	F	G	GD	EB	ED	DH	
A-DA80	19	40	6	15.5	6	30	5	M6	
A-DA90	24	50	8	20	7	40	5	M8	
A-DA100	28	60	8	24	7	50	5	M10	
A-DA112M	28	60	8	24	7	50	5	M10	
A-DA132	38	80	10	33	8	65	7.5	M12	
A-DA160	42	110	12	37	8	90	10	M16	

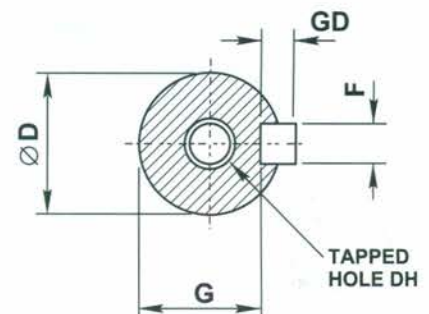

Dimensions

14

Foot, flange and face mounting - frame sizes 56 to 160 aluminium (B-DA)

IM B3
IM 1001
Mounting options

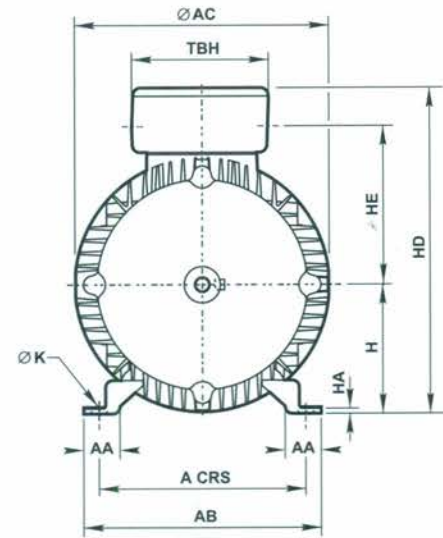
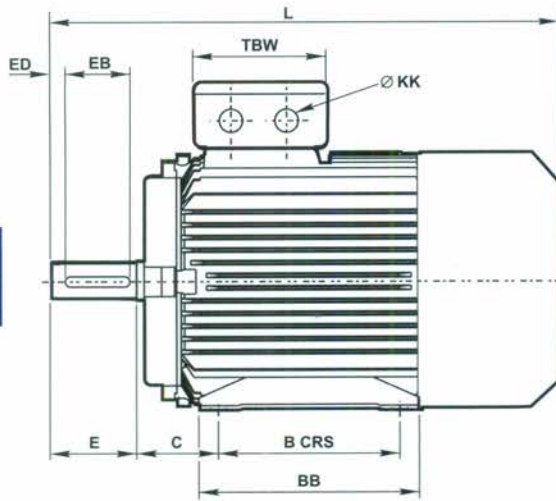

IM B5/IM B35
IM 3001/IM 2001
Mounting options

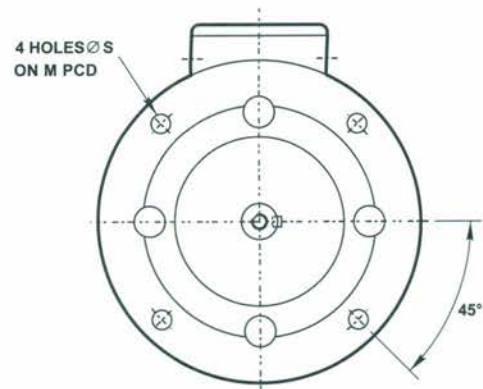
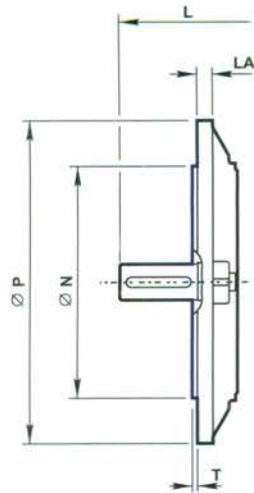

IM B14/IM B34
IM 3601/IM 2101
Mounting options

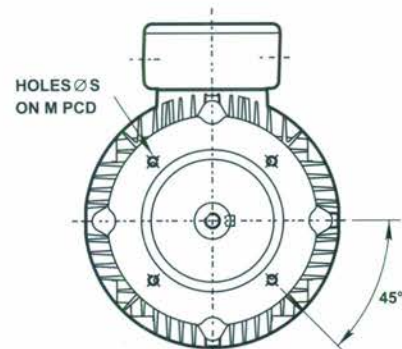
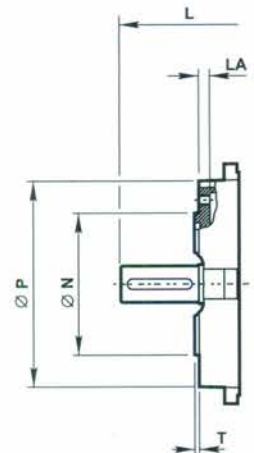

Dimensions

Foot, flange and face mounting - frame sizes 56 to 160 aluminium (B-DA)

General Type Aluminium	A	B	C	H	K	L	AA	AB	AC	BB	HA	HD	HE	Terminal box		KK
														TBW	TBH	
B-DA56M	90	71	36	56	5.8 x 8.3	199	23	111	113	88	7	153	72	86	86	1 x M20
B-DA63M	100	80	40	63	7 x 9.5	217	24	123	120	100	7	166	78	101	101	1 x M20
B-DA71M	112	90	45	71	7 x 11	245	26	138	136	110	8	183	87	101	101	1 x M20
B-DA80M	125	100	50	80	10 x 14	287	35	157	155	125	9	205	102.5	101	101	1 x M25
B-DA90S	140	100	56	90	10 x 14	310	37	173	175	125	10	228	107.5	109	109	1 x M25
B-DA90L	140	125	56	90	10 x 14	335	37	173	175	150	10	228	107.5	109	109	1 x M25
B-DA100L	160	140	63	100	12 x 16	383	40	196	195	172	11	252	121.5	109	109	1 x M32
B-DA112M	190	140	70	112	12 x 16	401	41	227	219	180	12	294	147.5	119	119	2 x M32
B-DA132S	216	140	89	132	12 x 16	475	51	262	258	186	15	320	153.5	119	119	2 x M32
B-DA132M	216	178	89	132	12 x 16	513	51	262	258	224	15	320	153.5	119	119	2 x M32
B-DA160M	254	210	108	160	15 x 18	609	55	304	315	260	18	397	194.5	155	164	2 x M40
B-DA160L	254	254	108	160	15 x 18	653	55	304	315	304	18	397	194.5	155	164	2 x M40

Flange & Face Type Aluminium	IM B5 mounting						IM B14 mounting					
	M	N	P	S	T	LA	M	N	P	S	T	LA
	B-DA56M	100	80	120	7	3	8	65	50	80	M5	2.5
B-DA63M	115	95	140	10	3	10	75	60	90	M5	2.5	-
B-DA71M	130	110	160	10	3.5	10	85	70	105	M6	2.5	-
B-DA80M	165	130	200	12	3.5	12	100	80	120	M6	3.0	-
B-DA90S	165	130	200	12	3.5	11	115	95	140	M8	3.0	14
B-DA90L	165	130	200	12	3.5	11	115	95	140	M8	3.0	14
B-DA100L	215	180	250	14.5	4.0	13	130	110	160	M8	3.5	15
B-DA112M	215	180	250	14.5	4.0	14	130	110	160	M8	3.5	15
B-DA132S	265	230	300	14.5	4.0	14	165	130	200	M10	3.5	17
B-DA132M	265	230	300	14.5	4.0	14	165	130	200	M10	3.5	17
B-DA160M	300	250	350	18.5	5.0	15	215	180	250	M12	4	-
B-DA160L	300	250	350	18.5	5.0	15	215	180	250	M12	4	-

Shaft Type Aluminium	D	E	F	G	GD	EB	ED	DH
	B-DA56	9	20	3	7.2	3	16	2
B-DA63	11	23	4	8.5	4	16	3.5	M4
B-DA71	14	30	5	11	5	25	2.5	M5
B-DA80	19	40	6	15.5	6	30	5	M6
B-DA90	24	50	8	20	7	40	5	M8
B-DA100	28	60	8	24	7	50	5	M10
B-DA112M	28	60	8	24	7	50	5	M10
B-DA132	38	80	10	33	8	65	7.5	M12
B-DA160	42	110	12	37	8	90	10	M16

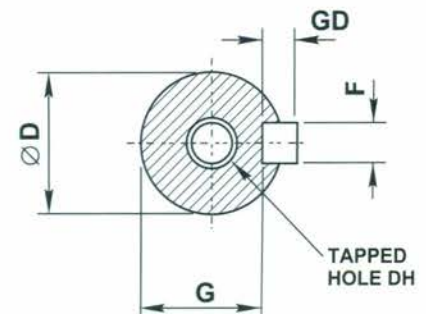

Dimensions

16

Foot, flange and face mounting - frame sizes 80 to 160 cast iron (A-DF)

IM B3
IM 1001
Mounting options

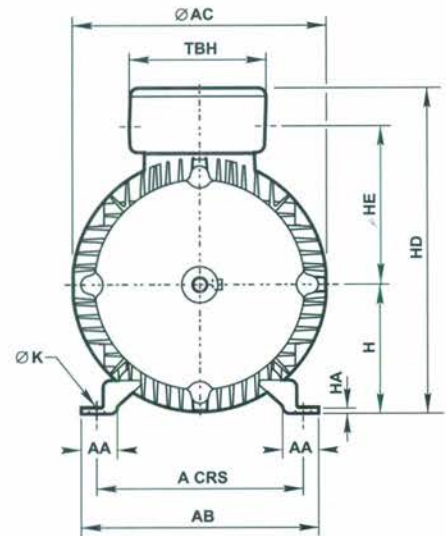
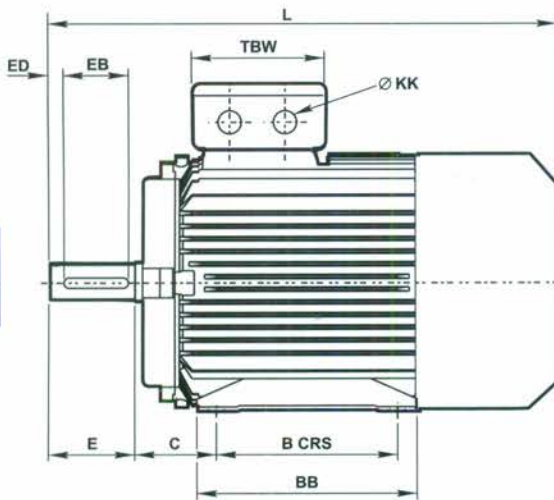

IM B5/IM B35
IM 3001/IM 2001
Mounting options

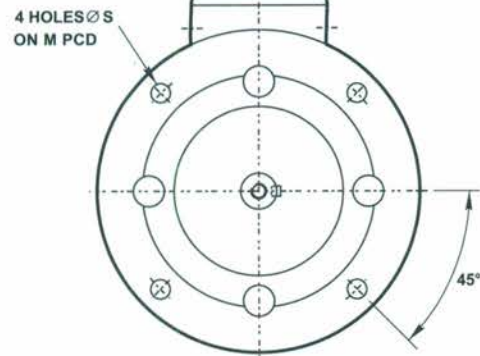
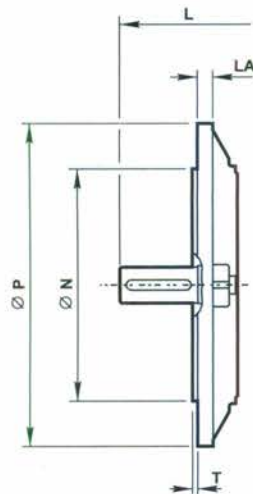

IM B14/IM B34
IM 3601/IM 2101
Mounting options

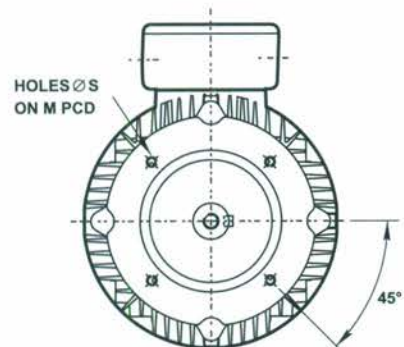
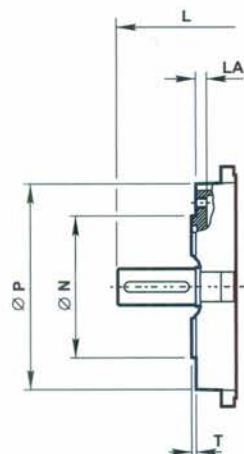

Dimensions

Foot, flange and face mounting - frame sizes 80 to 160 cast iron (A-DF)

General														Terminal box		
Type	A	B	C	H	K	L	AA	AB	AC	BB	HA	HD	HE	TBW	TBH	KK
Cast iron																
A-DF80M	125	100	50	80	10	304	34	160	167	150	10	227	-	102	102	1 x M25
A-DF90S	140	100	56	90	10	336	36	176	183	161	12	245	-	102	102	1 x M25
A-DF90L	140	125	56	90	10	361	36	176	183	186	12	245	-	102	102	1 x M25
A-DF100L	160	140	63	100	12	406	40	200	206	213	14	266	-	102	102	1 x M32
A-DF112M	190	140	70	112	12	452	50	240	220	225	15	294	-	110	118	2 x M32
A-DF132S	216	140	89	132	12	470	55	262	259	200	15	335	-	110	118	2 x M32
A-DF132M	216	178	89	132	12	508	55	262	259	238	15	335	-	110	118	2 x M32
A-DF160M	254	210	108	160	14.5	608	65	314	315	260	18	411	-	152	162	2 x M40
A-DF160L	254	254	108	160	14.5	652	65	314	315	304	18	411	-	152	162	2 x M40

Flange & Face												
Type	IM B5 mounting						IM B14 mounting					
	M	N	P	S	T	LA	M	N	P	S	T	LA
Cast iron												
A-DF80M	165	130	200	12	3.5	12	100	80	120	M6	3.0	-
A-DF90S	165	130	200	12	3.5	11	115	95	140	M8	3.0	14
A-DF90L	165	130	200	12	3.5	11	115	95	140	M8	3.0	14
A-DF100L	215	180	250	14.5	4.0	13	130	110	160	M8	3.5	15
A-DF112M	215	180	250	14.5	4.0	14	130	110	160	M8	3.5	15
A-DF132S	265	230	300	14.5	4.0	14	165	130	200	M10	3.5	17
A-DF132M	265	230	300	14.5	4.0	14	165	130	200	M10	3.5	17
A-DF160M	300	250	350	18.5	5.0	15	215	180	250	M12	4	-
A-DF160L	300	250	350	18.5	5.0	15	215	180	250	M12	4	-

Shaft								
Type	D	E	F	G	GD	EB	ED	DH
Cast iron								
A-DF80	19	40	6	15.5	6	30	5	M6
A-DF90	24	50	8	20	7	40	5	M8
A-DF100	28	60	8	24	7	50	5	M10
A-DF112M	28	60	8	24	7	50	5	M10
A-DF132	38	80	10	33	8	65	7.5	M12
A-DF160	42	110	12	37	8	90	10	M16

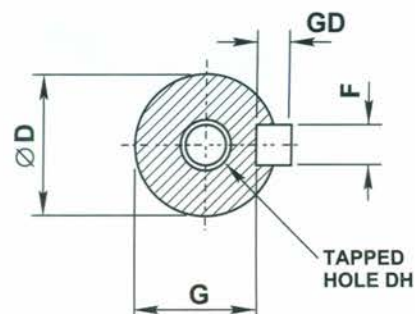

Dimensions

18 Foot, flange and face mounting - frame sizes 71 to 160 cast iron (B-DF)

IM B3
IM 1001
Mounting options

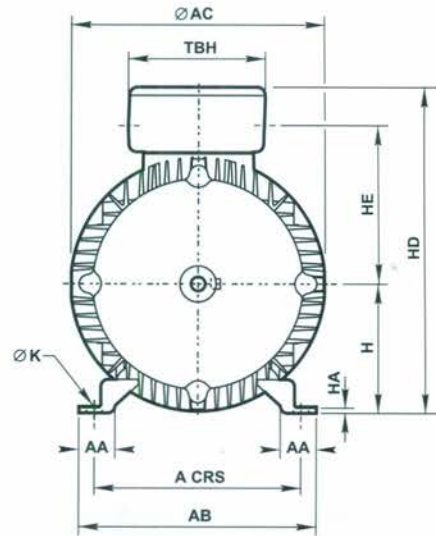
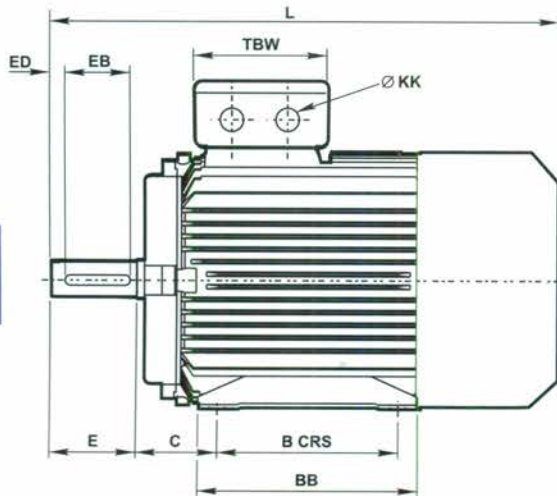

IM B5/IM B35
IM 3001/IM 2001
Mounting options

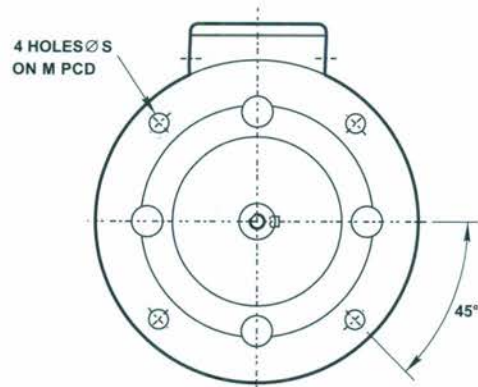
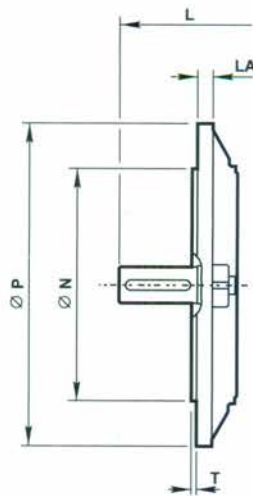

IM B14/IM B34
IM 3601/IM 2101
Mounting options

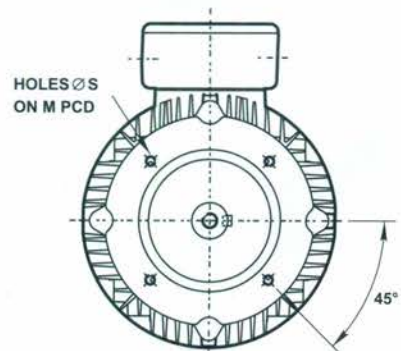
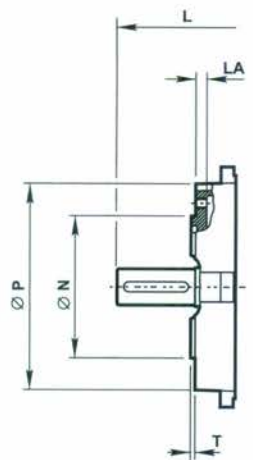

Dimensions

Foot, flange and face mounting - frame sizes 71 to 160 cast iron (B-DF)

General														Terminal box		
Type	A	B	C	H	K	L	AA	AB	AC	BB	HA	HD	HE	TBW	TBH	KK
B-DF71M	112	90	45	71	7	242	32	144	136	120	8	190	-	94	94	1 x M20
B-DF80M	125	100	50	80	10	284	34	160	156	130	10	211	-	94	94	1 x M25
B-DF90S	140	100	56	90	10	308	36	176	176	130	12	238	-	102	102	1 x M25
B-DF90L	140	125	56	90	10	333	36	176	176	155	12	238	-	102	102	1 x M25
B-DF100L	160	140	63	100	12	380	40	200	196	176	14	262	-	102	102	1 x M32
B-DF112M	190	140	70	112	12	394	45	226	220	180	15	295	-	110	118	2 x M32
B-DF132S	216	140	89	132	12	470	55	262	259	200	18	335	-	110	118	2 x M32
B-DF132M	216	178	89	132	12	508	55	262	259	238	18	335	-	110	118	2 x M32
B-DF160M	254	210	108	160	14.5	608	65	314	314	260	20	411	-	152	162	2 x M40
B-DF160L	254	254	108	160	14.5	652	65	314	314	304	20	411	-	152	162	2 x M40

Flange & Face													
Type	IM B5 mounting						IM B14 mounting						
	M	N	P	S	T	LA	M	N	P	S	T	LA	
B-DF71M	130	110	160	10	3.5	10	85	70	105	M6	2.5	-	
B-DF80M	165	130	200	12	3.5	12	100	80	120	M6	3.0	-	
B-DF90S	165	130	200	12	3.5	11	115	95	140	M8	3.0	14	
B-DF90L	165	130	200	12	3.5	11	115	95	140	M6	3.0	14	
B-DF100L	215	180	250	14.5	4.0	13	130	110	160	M8	3.5	15	
B-DF112M	215	180	250	14.5	4.0	14	130	110	160	M8	3.5	15	
B-DF132S	265	230	300	14.5	4.0	14	165	130	200	M10	3.5	17	
B-DF132M	265	230	300	14.5	4.0	14	165	130	200	M10	3.5	17	
B-DF160M	300	250	350	18.5	5.0	15	215	180	250	M12	4	-	
B-DF160L	300	250	350	18.5	5.0	15	215	180	250	M12	4	-	

Shaft								
Type	D	E	F	G	GD	EB	ED	DH
B-DF71	4	30	5	11	5	25	2.5	M5
B-DF80	19	40	6	15.5	6	30	5	M6
B-DF90	24	50	8	20	7	40	5	M8
B-DF100	28	60	8	24	7	50	5	M10
B-DF112M	28	60	8	24	7	50	5	M10
B-DF132	38	80	10	33	8	65	7.5	M12
B-DF160	42	110	12	37	8	90	10	M16

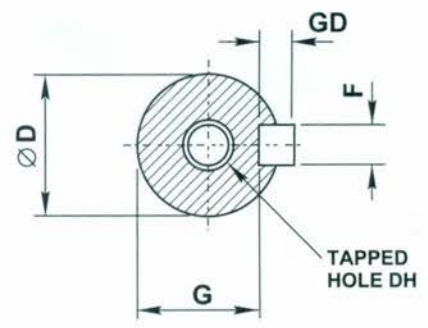

Dimensions

Foot and flange mounting - frame sizes 180 to 355 cast iron (A/AU-DF)

General																			
Type															Terminal box				
Cast iron	A	B	C	H	K	4 Pole +		2 Pole		AA	AB	AC	BB	HA	HD	HE	TBW	TBH	KK
A-DF180M	279	241	121	180	14.5	688	688	70	349	355	311	22	450	226.5	152	162	2 x M40		
A-DF180L	279	279	121	180	14.5	726	-	70	349	355	349	22	450	226.5	152	162	2 x M40		
A-DF200L	318	305	133	200	16.5	779	779	70	388	397	369	25	504	249	190	210	2 x M50		
AU-DF225S	356	286	149	225	18.5	824	-	75	431	446	368	28	561	278	190	210	2 x M50		
AU-DF225M	356	311	149	225	18.5	849	819	75	431	446	393	28	561	278	190	210	2 x M50		
AU-DF250M	406	349	168	250	24	910	910	80	484	485	445	30	610	303	218	248	2 x M63		
AU-DF280S	457	368	190	280	24	982	982	85	542	547	485	35	669	333	218	248	2 x M63		
AU-DF280M	457	419	190	280	24	1033	1033	85	542	547	536	35	669	333	218	248	2 x M63		
AU-DF315S	508	406	216	315	28	1224	1194	120	628	620	570	45	842	445	280	320	2 x M63		
AU-DF315M	508	457	216	315	28	1334	1304	120	628	620	680	45	842	445	280	320	2 x M63		
AU-DF315L	508	508	216	315	28	1334	1304	120	628	620	680	45	842	445	280	320	2 x M63		
AU-DF355M	610	560	254	355	28	1556	1487	116	726	698	750	52	997	540	330	380	2 x M63		
AU-DF355L	610	630	254	355	28	1556	1487	116	726	698	750	52	997	540	330	380	2 x M63		

Flange							
Type	IM B5, IM B35 mounting						
Cast iron	M	N	P	S	T	LA	
A-DF180M/L	300	250	350	18.5	5	15	
A-DF200L	350	300	400	18.5	5	17	
AU-DF225S/M	400	350	450	18.5	5	20	
AU-DF250	500	450	550	18.5	5	22	
AU-DF280	500	450	550	18.5	5	22	
AU-DF315S/M/L	600	550	660	24	6	22	
AU-DF355M/L	740	680	800	24	6	25	

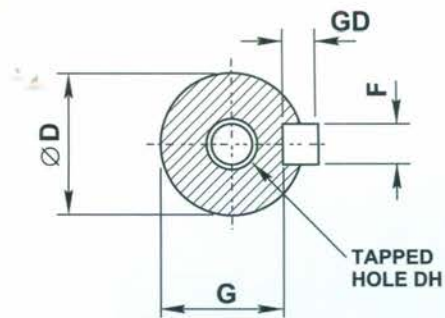

Shaft																			
Type	4 pole +									2 pole									
Cast iron	D	E	F	G	GD	EB	ED	DH		D	E	F	G	GD	EB	ED	DH		
A-DF180M/L	48	110	14	42.5	9	90	10	M16		48	110	14	42.5	9	90	10	M16		
AU-DF200L	55	110	16	49	10	100	5	M20		55	110	16	49	10	100	5	M20		
AU-DF225S	60	140	18	53	11	125	7.5	M20		-	-	-	-	-	-	-	-		
AU-DF225M	60	140	18	53	11	125	7.5	M20		55	110	16	49	10	100	5	M20		
AU-DF250M	65	140	18	58	11	125	7.5	M20		60	140	18	53	11	125	7.5	M20		
AU-DF280S/M	75	140	20	67.5	12	125	7.5	M20		65	140	18	58	11	125	7.5	M20		
AU-DF315S/M/L	80	170	22	71	14	160	5	M20		65	140	18	58	11	125	7.5	M20		
AU-DF355M/L	100	210	28	90	16	180	15	M24		75	140	20	67.5	12	125	7.5	M20		

Dimensions

22

Foot and flange mounting - frame sizes 180 to 355 cast iron (B/BU-DF)

IM B3
IM 1001

Mounting options

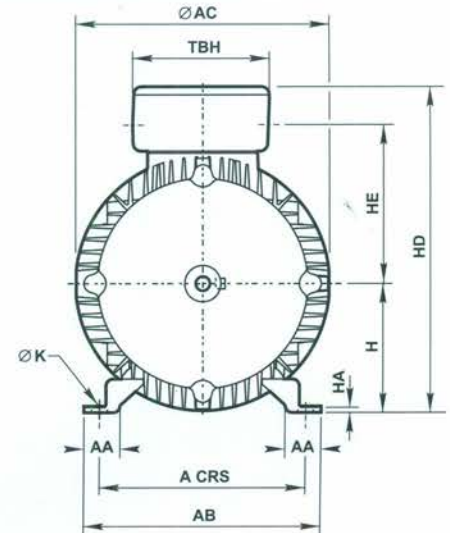
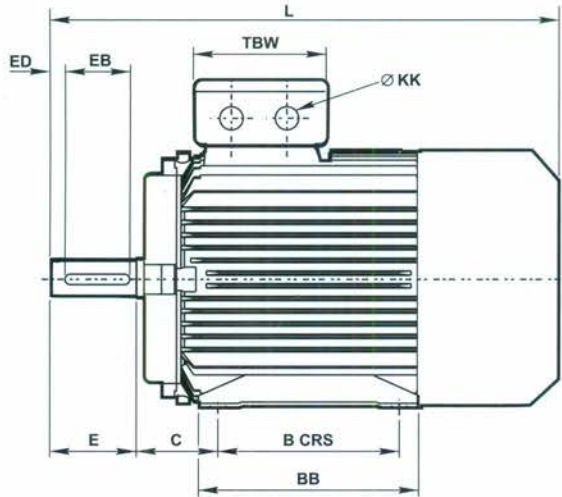

IM B5/IM B35
IM 3001/IM 2001

Mounting options

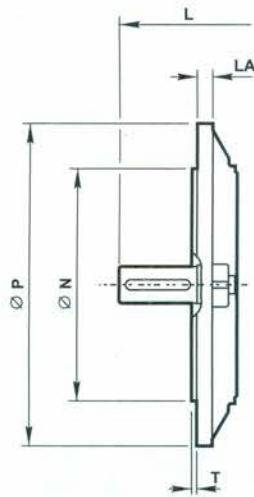

4 HOLES Ø S
ON M PCD

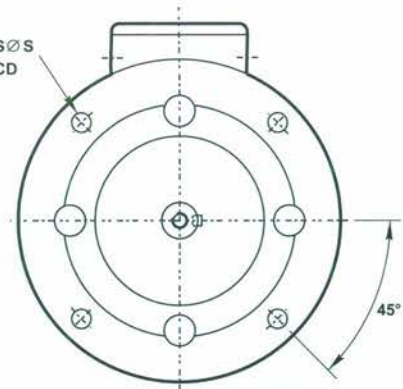

Up to 200 frame

8 HOLES Ø S
ON M PCD (1)

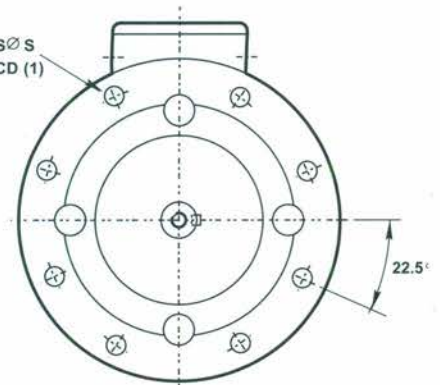

8 holes at 22.5° for flanges to suit 225 frames and above to European specification

Dimensions

Foot and flange mounting - frame sizes 180 to 355 cast iron (B/BU-DF)

General																			
Type															Terminal box				
Cast iron	A	B	C	H	K	4 Pole +		2 Pole		AA	AB	AC	BB	HA	HD	HE	TBW	TBH	KK
B-DF180M	279	241	121	180	14.5	688	688	70	349	355	311	22	450	229	152	162	2 x M40		
B-DF180L	279	279	121	180	14.5	726	726	70	349	355	349	22	450	229	152	162	2 x M40		
B-DF200L	318	305	133	200	16.5	771	771	70	388	397	369	25	504	249	190	210	2 x M50		
BU-DF225S	356	286	149	225	18.5	824	-	75	431	446	368	28	552	270	190	210	2 x M50		
BU-DF225M	356	311	149	225	18.5	849	819	75	431	446	393	28	552	270	190	210	2 x M50		
BU-DF250M	406	349	168	250	24	910	910	80	484	485	445	30	613	299	218	248	2 x M63		
BU-DF280S	457	368	190	280	24	982	982	85	542	547	485	35	667	333	218	248	2 x M63		
BU-DF280M	457	419	190	280	24	1033	1033	85	542	547	536	35	667	333	218	248	2 x M63		
BU-DF315S	508	406	216	315	28	1208	1178	120	628	620	570	45	842	445	280	320	2 x M63		
BU-DF315M	508	457	216	315	28	1318	1288	120	628	620	680	45	842	445	280	320	2 x M63		
BU-DF315L	508	508	216	315	28	1318	1288	120	628	620	680	45	842	445	280	320	2 x M63		
BU-DF355M	610	560	254	355	28	1556	1487	116	726	698	750	52	997	544.5	330	380	2 x M63		
BU-DF355L	610	630	254	355	28	1556	1487	116	726	698	750	52	997	544.5	330	380	2 x M63		

Flange						
Type	IM B5, IM B35 mounting					
Cast iron	M	N	P	S	T	LA
B-DF180M/L	300	250	350	18.5	5	15
B-DF200L	350	300	400	18.5	5	17
BU-DF225S/M	400	350	450	18.5	5	20
BU-DF250	500	450	550	18.5	5	22
BU-DF280	500	450	550	18.5	5	22
BU-DF315S/M/L	600	550	660	24	6	22
BU-DF355M/L	740	680	800	24	6	25

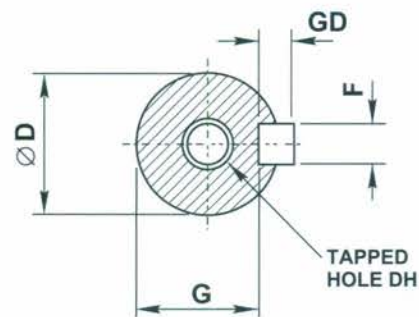

Shaft																	
Type	4 pole +								2 pole								
Cast iron	D	E	F	G	GD	EB	ED	DH	D	E	F	G	GD	EB	ED	DH	
B-DF180M/L	48	110	14	42.5	9	90	10	M16	48	110	14	42.5	9	90	10	M16	
BU-DF200L	55	110	16	49	10	100	5	M20	55	110	16	49	10	100	5	M20	
BU-DF225S	60	140	18	53	11	125	7.5	M20	-	-	-	-	-	-	-	-	
BU-DF225M	60	140	18	53	11	125	7.5	M20	55	110	16	49	10	100	5	M20	
BU-DF250M	65	140	18	58	11	125	7.5	M20	60	140	18	53	11	125	7.5	M20	
BU-DF280S/M	75	140	20	67.5	12	125	7.5	M20	65	140	18	58	11	125	7.5	M20	
BU-DF315S/M/L	80	170	22	71	14	160	5	M20	65	140	18	58	11	125	7.5	M20	
BU-DF355M/L	100	210	28	90	16	180	15	M24	75	140	20	67.5	12	125	7.5	M20	

Dimensions

24

Foot and flange mounting - frame sizes 355LB to 450 cast iron (BU-DF)

IM B3
IM 1001
Mounting options

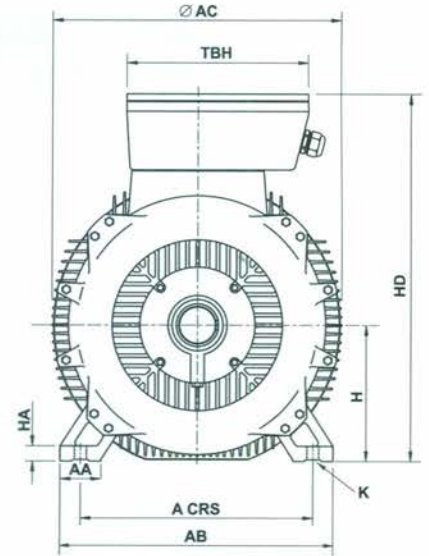
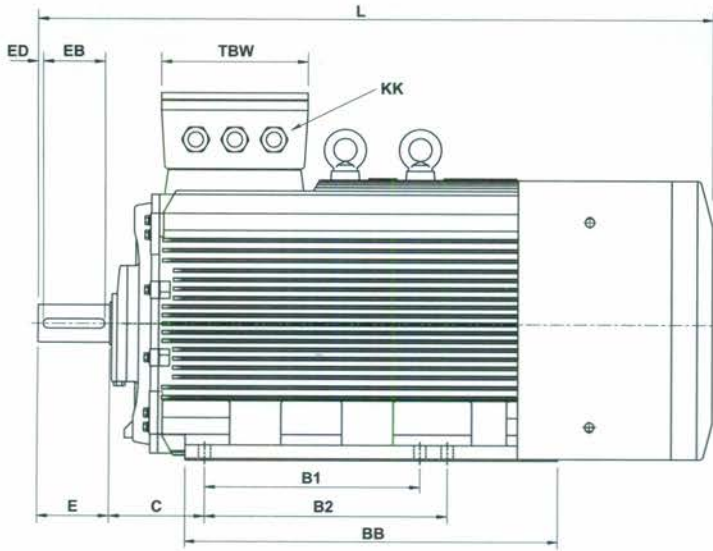

IM B35
IM 2001
Mounting options

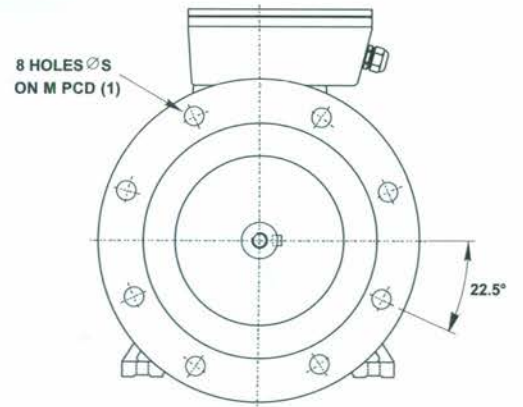
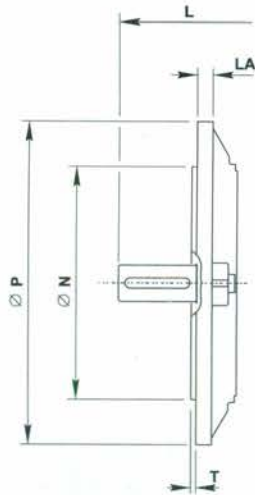

Dimension

Foot and flange mounting - frame sizes 355LB to 450 cast iron (BU-DF)

General																		
Type																Terminal box		
Cast iron	A	B1	B2	C	H	K	6, 8 Pole			4 Pole			2 Pole			TBW	TBH	KK
							L	L	L	AA	AB	AC	BB	HA	HD			
BU-DF355B +	630	800	-	224	355	35	1918	1898	1863	116	760	745	1140	52	1120	392	572	3 x M63
BU-DF400M	686	630	710	280	400	36	1881	1881	1820	120	806	860	1090	52	1080	430	485	3 x M63
BU-DF400L	686	630	710	280	400	36	1881	1881	1820	120	806	860	1090	55	1080	430	485	3 x M63
BU-DF450M	800	900	1000	250	450	36	2200	2200	2050	150	950	950	1200	62	1400	460	530	3 x M63
BU-DF450L	800	900	1000	250	450	36	2200	2200	2050	150	950	950	1200	62	1400	460	530	3 x M63

Flange							
Type	IM B5, IM B35 mounting						
Cast iron	M	N	P	S	T	LA	
BU-DF355	840	780	800	24	6	-	
BU-DF400	940	880	1000	28	6	-	
BU-DF450	1040	980	1100	32	8	-	

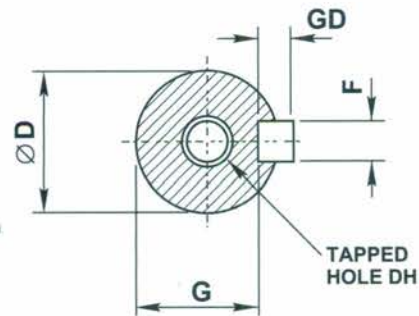

Shaft																	
Type	4 pole +								2 pole								
Cast iron	D	E	F	G	GD	EB	ED	DH	D	E	F	G	GD	EB	ED	DH	
BU-DF355	110	210	28	86	16	160	5	M24	80	170	22	67.5	14	130	5	M20	
BU-DF400	110	210	28	100	16	180	15	M24	85	170	22	76	14	140	15	M24	
BU-DF450	130	250	32	119	16	180	15	M24	90	170	25	86	14	140	15	M24	

Dimension pages notes & mounting codes

26

Page notes

Shaft		
Dim D	Tol	Limits
11 to 14	j6	+0.008 -0.003
19 to 28	j6	+0.009 -0.004
38 to 48	k6	+0.018 +0.002
55 to 80	m6	+0.030 +0.011
85 to 110	m6	+0.035 +0.013

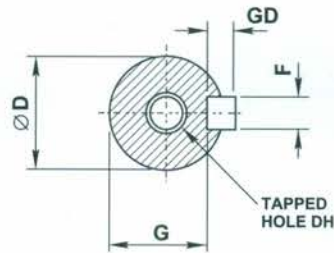

All dimensions in millimetres

Cable entry can be arranged in any one of four positions at 90° intervals

Dimensions should not be used for installation purposes unless specially endorsed

B5 mounted motors have suffix '-D' in the frame reference, eg A-DA132MA-D and B3/B5 mounted motors have suffix '-H' in the frame reference, eg A-DA132MA-H

B14 mounted motors have suffix 'C' in the frame reference, eg A-DA132MA-C and B3/B14 mounted motors have suffix '-H' in the frame reference, eg A-DA132MA-H

Note

355LB frame and above, flange only available when B35 mounted (foot & flange).

Flange	IEC 60072	
	Tol	Limits
110	j6	+0.013 -0.009
130	j6	+0.014 -0.011
230 to 250	j6	+0.016 -0.013
300	j6	+0.016 -0.016
350	j6	+0.018 -0.018
450	j6	+0.020 -0.020
550	j6	+0.022 -0.022
680	js6	+0.025 -0.025

Face	IEC 60072	
	Tol	Limits
70 and 80	j6	+0.012 -0.007
95 and 110	j6	+0.013 -0.009
130	j6	+0.014 -0.011
230	j6	+0.016 -0.013

Mounting codes

Horizontal shaft:



**IM B3
IM 1001**
foot mounted

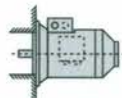

**IM B5
IM 3001**
flange at DE
no feet



**IM B6
IM 1051**
foot wall mounted with
feet on left-hand side
when viewed from DE



**IM B7
IM 1061**
foot wall mounted with
feet on right-hand side
when viewed from DE



**IM B8
IM 1071**
ceiling mounted
with feet
above motor



**IM B14
IM 3601**
face at DE
no feet

Vertical shaft:



**IM V1
IM 3011**
flange at DE
shaft down
no feet



**IM V3
IM 3031**
flange at DE
shaft up
no feet



**IM V5
IM 1011**
vertical foot
wall mounted
shaft down

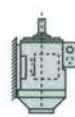

**IM V6
IM 1031**
vertical foot
wall mounted
shaft up



**IM V18
IM 3611**
face at DE
shaft down
no feet



**IM V19
IM 3631**
face at DE
shaft up
no feet

Technical information

Mechanical

Bearing arrangements

Bearing references and oilseals for horizontally mounted motors only						
Type		Poles	Bearings ¹¹⁾		Oilseals ¹²⁾	
Aluminium	Cast iron		Drive end	Non-drive end	Drive end	Non-drive end
B / A-DA56	-	All	6201ZZ	6201ZZ	12 x 25 x 7	12 x 25 x 7
B / A-DA63M	-	All	6201ZZ	6201ZZ	12 x 25 x 7	12 x 25 x 7
B / A-DA71M	B / A-DF71M	All	6202ZZ	6202ZZ	15 x 30 x 7	15 x 30 x 7
B / A-DA80M	B / A-DF80M	All	6204ZZ	6204ZZ	20 x 35 x 7	20 x 35 x 7
B / A-DA90S/L	B / A-DF90S/L	All	6205ZZ	6205ZZ	25 x 40 x 7	25 x 40 x 7
B / A-DA100L	B / A-DF100L	All	6206ZZ	6206ZZ	30 x 47 x 7	30 x 47 x 7
B / A-DA112M	B / A-DF112M	All	6306ZZ	6306ZZ	30 x 47 x 7	30 x 47 x 7
B / A-DA132S/M	B / A-DF132S/M	All	6308ZZ	6308ZZ	40 x 62 x 7	40 x 62 x 7
B / A-DA160M/L	B / A-DF160M/L	All	6309ZZ	6309ZZ	45 x 62 x 12	45 x 62 x 12
-	B / A-DF180M/L	All	6311	6311	55 x 75 x 12	55 x 75 x 12
-	B / A-DF200L	All	6312	6312	60 x 80 x 12	60 x 80 x 12
-	B / AU-DF225S/M	All	6313	6313	65 x 90 x 12	65 x 90 x 12
-	B / AU-DF250S/M	All	6314	6314	70 x 90 x 12	70 x 90 x 12
-	B / AU-DF280S/M	2	6314	6314	70 x 90 x 12	70 x 90 x 12
-	B / AU-DF280S/M	4 up	6317	6317	85 x 110 x 12	85 x 110 x 12
-	B / AU-DF315S/M/L	2	6317	6317	85 x 110 x 12	85 x 110 x 12
-	B / AU-DF315S/M/L	4 up	6319	6319	95 x 120 x 12	95 x 120 x 12
-	B / AU-DF355M/L	2	6319	6319	95 x 120 x 12	95 x 120 x 12
-	B / AU-DF355M/L	4 up	NU322	6322	110 x 140 x 14	110 x 140 x 14
-	BU-DF400	2	NU2194E & 6219	7219B	84.5 x 97 x 10	84.5 x 97 x 10
-	BU-DF400	4 up	NU326E	6326	119 x 140 x 14	119 x 140 x 14
-	BU-DF450	2	NU222E & 6222	7222B	110 x 124 x 12	110 x 124 x 12
-	BU-DF450	4 up	6328	6328	140 x 154 x 15	140 x 154 x 15

¹¹⁾ Frame sizes 56-160 have sealed for life bearings with C3 clearances. Frame sizes 180-355 bearings have regreasing facilities with C3 clearance.

¹²⁾ Sizes given are in mm and represent bore x outside diameter x width.

The seal material used on all frame sizes and all polarity is nitrile rubber (NBR).

Relubrication intervals for bearing operating temperature up to 70°C x 10 ³ hours								
Type	3000 min ⁻¹		1500 min ⁻¹		1000 min ⁻¹		750 min ⁻¹	
	Horizontal	Vertical	Horizontal	Vertical	Horizontal	Vertical	Horizontal	Vertical
B / A-DF180M/L	3	1.75	8	4.25	12	6	12	6
B / A-DF200L	3	1.75	8	4.25	12	6	12	6
B / AU-DF225S	3	1.5	8	4	11	5.5	11	5.5
B / AU-DF225M	3	1.5	8	4	11	5.5	11	5.5
B / AU-DF250M	2	1	7.5	3.75	10.5	5.25	10.5	5.25
B / AU-DF280S	1.5	0.75	7	3.5	10	5	10	5
B / AU-DF280M	1.5	0.75	7	3.5	10	5	10	5
B / AU-DF315S	1	0.5	3.8	1.9	7.5	3.75	7.5	3.75
B / AU-DF315M	1	0.5	3.8	1.9	7.5	3.75	7.5	3.75
B / AU-DF315L	1	0.5	3.8	1.9	7.5	3.75	7.5	3.75
B / AU-DF355M	1	0.5	2.5	1.25	2	1	2	1
B / AU-DF355L	1	0.5	2.5	1.25	2	1	2	1
BU-DF400	-	-	-	-	-	-	-	-
BU-DF450	-	-	-	-	-	-	-	-

Sealed for life bearings are fitted with a premium quality grease to ensure exceptional reliability under a wide range of operating conditions. Under normal operating conditions, a grease life of more than 25,000 hours can be achieved. The regreasing time should be reduced if the bearing operating temperature is in excess of 70°C.

Performance data notes

28

Speed / torque & speed / current curves

DOL starting

Typical speed/current curve

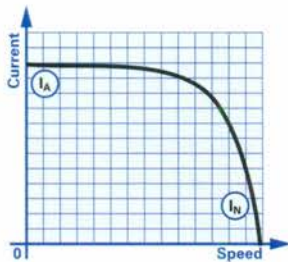

Typical speed/torque curve

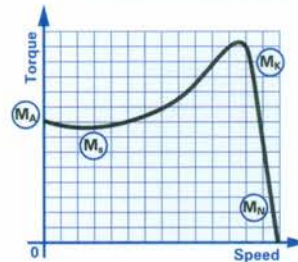

- (I_A) Starting current
- (I_N) Full load current
- (M_A) Starting torque or locked rotor torque
- (M_S) Pull up torque or run up torque
- (M_K) Pull out torque or breakdown torque
- (M_N) Full load torque

Torque/speed curves for specific motors can be supplied on request.

During the run up period in Star, there must be an adequate excess of motor torque over the load torque. The change to Delta must not occur until the motor is near the operating speed. Refer to Brook Crompton for running up against a load in excess of 70% full load during Star Delta starting.

Performance figures are subject to IEC tolerances. Performance figures are based on a 400 volt winding.

$$J \text{ [WK}^2 \text{ or WR}^2] = \frac{GD^2}{4}$$

$$J \text{ in lb ft}^2 = \frac{\text{kgm}^2}{0.042}$$

Connection diagrams

Star Delta	Dual voltage	Thermistors - (PTC)	Thermostats - (PTO)
<p>Motors => 4kW</p>		<p>Connect to thermistor control unit.</p>	<p>Connect to overload protection circuit</p>