



Enriching Lives

Three Phase AC Induction Motor

indus3

EFFICIENT ■ SILENT ■ HEAVY-DUTY



KIRLOSKAR BROTHERS LIMITED



Enriching Lives



When needs are diverse, solutions need to be as diverse too. Kirloskar Brothers Ltd. (KBL) the flagship company of Kirloskar Group has been into the manufacturing of pumps and motors for over twelve decades. Having mastered the art of providing quality products, KBL proudly introduces the new series *indus3* motors, designed to meet the diverse needs of future industry.

With superb efficiency, heavy-duty performance and unmatched qualities, *indus3* will deliver effective solutions. Apart from this, the product promises total customer delight, Our pre & post sales support teams will be always on their toes to ensure your experience with. *indus3* is the one you will value for a lifetime.

Today, over 100 countries walk hand in hand with the Kirloskar trust, and it is the trust, which has seen us producing the widest range of pumps & motors.

We are committed to the total satisfaction of our customers.

An Overview of Manufacturing Units of KBL



KIRLOSKARVADI, MAHARASHTRA



SHIRVAL, MAHARASHTRA



DEWAS, MADHYA PRADESH



KONDHAPURI, MAHARASHTRA

Well Designed Efficient, Silent and Heavy Duty Motor

EFFICIENT



SILENT

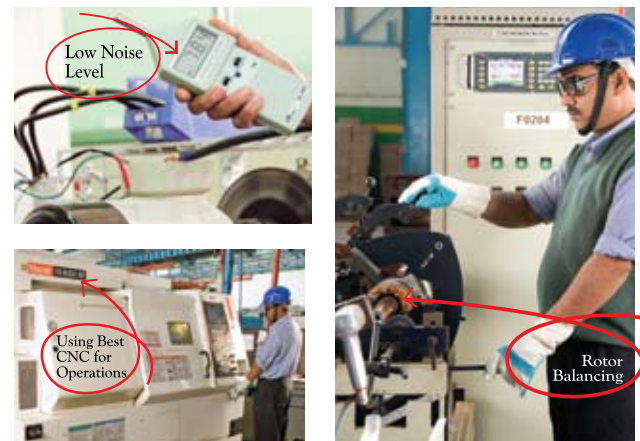

HEAVY-DUTY

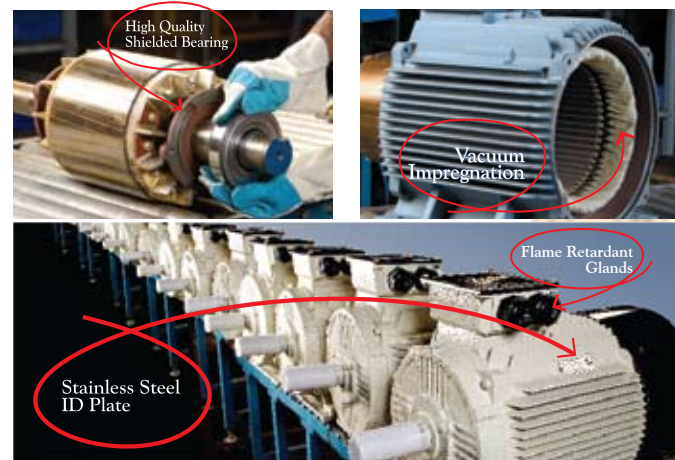

1 Higher efficiency point in motor means a saving of Rs 400/- per year per HP on three shifty basis. Similarly, a 50 HP motor saves upto Rs. 2, 00,000 in 10 years, which is 4 times of the motor cost.

Introduction

The Indus3 series general purpose AC three phase induction motors have been designed and engineered in compliance with latest technical knowledge and production processes and has attained highest standards in both the fields.

Features:

1. Efficiency exceeds Eff2 level as per IS 12615.
2. Large top terminal box for easy cable entry: its direction can be rotated in steps of 90°.
3. Motors upto 225 frames are provided with shielded ball bearing with external greasing arrangement from frame 160 & above making it convenient in case bearings are replaced by non shielded bearings.
4. Compact design & better aesthetics.
5. Rugged CI construction.

Applications:

The Indus3 series induction motors are suitable for varied application in industries such as textile, paper, rubber, petrochemical, power generation, cement, steel, sugar, agricultural implements, pumps, machine tools, compressors, etc.

Specifications

Performance	As per IS 325 and IS 12615
Frame	80 - 280; Dimensions as per IS1231
Output	0.55kW to 90kW
Voltage	415 ± 10% V
Frequency	50Hz ± 5%
Combined Variation	± 10% (Absolute)
Insulation	Class 'F'
Rating/ Duty	Continuous/S1
Mounting	Foot Mounting: B3, B6, B7, B8, V5,V6 Flange Mounting: B5,V1,V3 Face Mounting: B14, V18,V19 Also other mounting combinations can be offered
Ambient/ Temperature Rise	50° C/ 70° C (Limited to Class 'B' Temperature rise)
Enclosure	TEFC
Degree of Protection	IP55 as per IS: 4691
Altitude	Up to 1000m above mean sea level
Direction of Rotation	Bi-directional

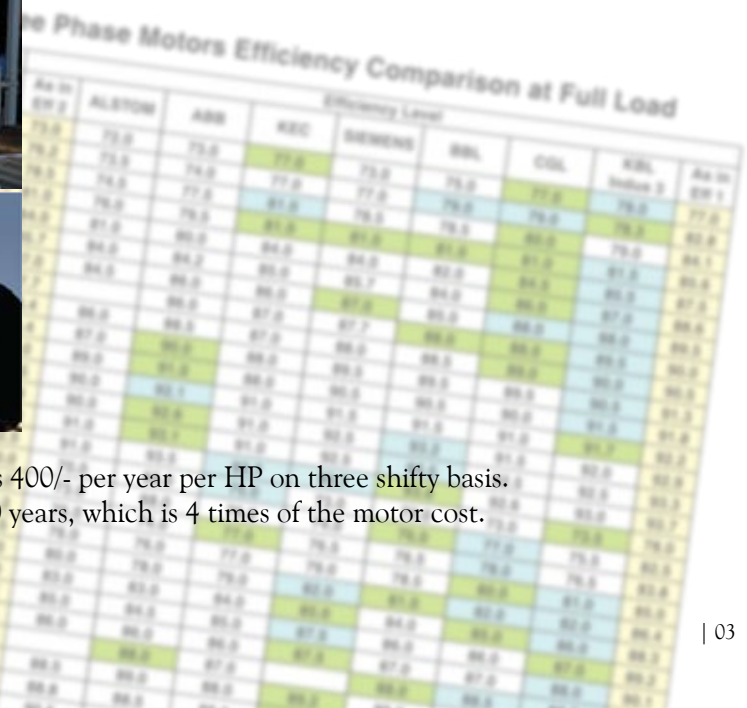

Conformance to Standards:

Kirloskar Indus3 series three phase induction motors are specially designed in accordance with latest BIS standard specifications and relevant IEC publications.

Standard Specifications	BIS	IEC
Three Phase Induction motor specifications	IS 325	60034 - 1
Method of determination of efficiency of rotating electrical machines	IS 4889	60034 - 2
Degree of protection	IS 4691	60034 - 5
Designation of method of cooling of rotating electrical machines	IS 6362	60034 - 6
Type of construction and mounting arrangement for rotating electrical machines	IS 2253	60034 - 7
Terminal marking and direction of rotation for electrical rotating machines	IS 4728	60034 - 8
Permissible limit of noise level for rotating Electrical machines	IS 12065	60034 - 9
Mechanical vibration of rotating electric machines with shaft height 56 mm and above - Measurement, Evaluation and limit of vibration severity	IS 12075	60034 - 14
Three phase foot mounted induction motors dimensions	IS 1231	-
Three phase flange mounted AC induction motors dimensions	IS 2223	60072 -1
Specification for energy efficient Three Phase Induction motor	IS 12615	-
Class of insulation	IS 1271	60085

Mechanical Parameters

Stator:

Over the entire range, the series is in rugged CI construction. The stator body and end shields are machined to close tolerance for providing perfect alignment and fits.

Rotor:

The squirrel cage rotors are made of Aluminum pressure die cast, locked positively on the shaft by shrink fitting process thus forms a compact unit. The shafts are made of C45 Carbon Steel. Shaft and rotor surface are provided with a light golden yellow rust protective coat.

Bearings:

Motors upto 225 frames are provided with deep groove pre lubricated ZZ type ball bearing at both sides. These bearings are shielded for life and require no maintenance.

External greasing arrangement is provided for motors from 160 to 225 frames to facilitate periodic greasing in case ZZ type bearings are replaced with standard non-sealed bearings.

Motors in frame 250 & 280 are provided with non shielded deep groove ball bearings with external on line greasing arrangement.

FRAME	BEARINGS	
	DE	NDE
KI 80	6204ZZ	6204ZZ
KI 90	6205ZZ	6205ZZ
KI 100	6206ZZ	6206ZZ
KI 112	6306ZZ	6306ZZ
KI 132	6308ZZ	6308ZZ
KI 160	6309ZZ	6309ZZ
KI 180	6311ZZ	6311ZZ
KI 200	6312ZZ	6312ZZ
KI 225	6313ZZ	6313ZZ
KI 250 M	6314	6314
KI 280S-2 POLE	6314	6314
KI 280M-4,6,8 POLE	6317	6317

Cooling Fan and Cover: The external cooling fan is made of Polypropylene reinforced with fiberglass material and designed aerodynamically to deliver sufficient air. The fan cover is manufactured from corrosion resistance sheet Steel. All motors are suitable for bi-directional rotation.

Terminal Box and Cover: Large terminal box provided on the top and designed suitably for entry and termination of aluminum cables. Terminal box can be rotated in a step of 90° through 360° to allow easy entry of cable in desired direction. Connection diagram provided inside the terminal cover.

Electrical Parameters

Magnetic Elements: Stator and Rotor laminations are made from low carbon electrical steel. Low loss coefficient is obtained by a special annealing treatment of the laminations.

Windings: Stator winding of Indus3 series motors are exclusively made of high grade enameled Copper wire and with class 'F' insulating materials. Mechanical strength of the windings is ensured by impregnating them under vacuum with varnish of high solid content.

The motors rated up to 2.2kW will be internally connected in Star for 415V, 50Hz supply three leads are brought out to the terminal box. Motors 3.7 kW and above are Delta connected for 415V, 50Hz and six leads of the winding are brought out to the terminal box.

Shipping Specifications

FRAME SIZE	SHIPPING DIMENSION IN MM			NETT WT. KG	GROSS WT.KG.
	Length	Width	Height		
KI 80	355	233	305	18	20
KI 90S	412	247	335	22	25
KI 90L	412	247	335	26	30
KI 100L	452	272	360	35	40
KI 100L-5C2	487	272	360	36	41
KI 112M	472	312	391	47	52
KI 132S	586	345	450	72	78
KI 132M	586	345	450	85	92
KI 160M	810	485	550	122	170
KI 160L	810	485	550	145	195
KI 180M	860	505	615	174	230
KI 180L	860	505	615	192	250
KI 200L	970	645	672	257	340
KI 225S	1030	685	722	290	370
KI 225M	1030	685	722	320	415
KI 250M	1110	700	800	390	500
KI 280S	1160	760	850	520	650
KI 280M	1215	760	850	600	750

Performance Data

3 Phase TEFC/ Squirrel Cage Motor, 2Pole – 3000 rpm Synchronous Speed

Eff2

Frame	Rated Power		Rated Current	Speed	% Eff.	Power Factor	Max. Torque	Min. Torque	Locked Torque	Locked Current	Noise Level At No Load	Vib. Speed
					(FL)		Rated Torque	Rated Torque	Rated Torque	Rated Current	dB (A)	mm/s
	kW	HP	Amp	RPM			$\frac{T_{max}}{T_n}$	$\frac{T_{min}}{T_n}$	$\frac{T_{st}}{T_n}$	$\frac{I_{st}}{I_n}$		
KI 80	0.75	1	1.7	2850	78.0	0.83	2.3	1.5	2.2	7.0	67	1.8
KI 80	1.1	1.5	2.4	2850	78.3	0.84	2.3	1.5	2.2	7.0	67	1.8
KI 90S	1.5	2	3.2	2870	79.0	0.85	2.3	1.5	2.2	7.0	72	1.8
KI 90L	2.2	3	4.4	2870	81.5	0.86	2.3	1.4	2.2	7.0	72	1.8
KI 100L	3.7	5	7.0	2860	85.5	0.87	2.3	1.4	2.1	6.0	75	1.8
KI 112M	5.5	7.5	10.0	2920	87.0	0.88	2.3	1.4	2.2	6.5	77	1.8
KI 132S	5.5	7.5	10.0	2920	87.0	0.88	2.3	1.2	2.2	6.5	80	1.8
KI 132S	7.5	10	13.5	2920	88.0	0.88	2.3	1.2	2.1	6.5	80	1.8
KI 132M	9.3	12.5	16.6	2893	89.5	0.88	2.3	1.2	2.1	6.5	80	1.8
KI 160M	11	15	19.5	2940	90.0	0.89	2.3	1.2	2.1	6.0	86	2.8
KI 160M	15	20	26.0	2940	90.5	0.89	2.3	1.2	2.1	6.0	86	2.8
KI 160L	18.5	25	31.7	2940	91.5	0.89	2.3	1.1	2.1	6.0	86	2.8
KI 180M	22	30	38.0	2950	91.7	0.89	2.3	1.1	2.1	6.0	89	2.8
KI 200L	30	40	51.0	2950	92.0	0.89	2.3	1.1	1.9	5.5	92	2.8
KI 200L	37	50	62.0	2960	92.5	0.90	2.3	1.1	1.9	5.5	92	2.8
KI 225M	45	60	75.0	2970	93.0	0.90	2.3	1.0	1.7	5.5	92	2.8
KI 250 M	55	75	92	2975	93.5	0.91	2.3	1.5	2.0	6.0	93	3.5
KI 280 S	75	100	124	2975	94.8	0.91	2.3	1.5	2.0	6.0	94	3.5
KI 280 M	90	120	147	2975	95.0	0.91	2.3	1.5	2.0	6.0	94	3.5

3 Phase TEFC/ Squirrel Cage Motor, 4Pole – 1500 rpm Synchronous Speed

Eff2

Frame	Rated Power		Rated Current	Speed	% Eff.	Power Factor	Max. Torque	Min. Torque	Locked Torque	Locked Current	Noise Level At No Load	Vib. Speed
					(FL)		Rated Torque	Rated Torque	Rated Torque	Rated Current	dB (A)	mm/s
	kW	HP	Amp	RPM			$\frac{T_{max}}{T_n}$	$\frac{T_{min}}{T_n}$	$\frac{T_{st}}{T_n}$	$\frac{I_{st}}{I_n}$		
KI 80	0.55	0.75	1.4	1405	73.5	0.75	2.3	1.7	2.4	6.0	58	1.8
KI 80	0.75	1	1.8	1405	75.5	0.77	2.3	1.6	2.4	6.0	58	1.8
KI 90S	1.1	1.5	2.6	1410	76.5	0.78	2.3	1.6	2.3	6.5	62	1.8
KI 90L	1.5	2	3.4	1410	81.0	0.78	2.3	1.6	2.3	6.5	62	1.8
KI100L	2.2	3	4.7	1430	82.0	0.80	2.3	1.5	2.3	7.1	65	1.8
KI 112M	3.7	5	7.6	1450	86.0	0.80	2.3	1.5	2.3	7.1	68	1.8
KI 132S	5.5	7.5	11.0	1455	87.0	0.81	2.3	1.4	2.3	7.1	71	1.8
KI 132M	7.5	10	14.0	1455	88.0	0.85	2.3	1.4	2.3	7.1	71	1.8
KI 132M	9.3	12.5	17.5	1440	88.5	0.85	2.3	1.2	2.3	6.0	80	1.8
KI 160M	11	15	20.0	1470	90.5	0.85	2.3	1.4	2.1	7.7	75	2.8
KI 160L	15	20	27.5	1470	91.0	0.84	2.3	1.4	2.1	7.7	75	2.8
KI 180M	18.5	25	32.5	1475	92.5	0.86	2.3	1.2	2.1	7.7	77	2.8
KI 180L	22	30	38.5	1475	92.8	0.86	2.3	1.2	2.1	7.7	77	2.8
KI 200L	30	40	54.1	1480	93.2	0.86	2.3	1.2	2.1	7.3	79	2.8
KI 225S	37	50	63.0	1480	94.0	0.87	2.3	1.2	1.7	7.3	81	2.8
KI 225M	45	60	77.0	1480	94.2	0.87	2.3	1.1	1.8	7.3	81	2.8
KI 250 M	55	75	92	1485	94.5	0.9	2.3	1.5	2.0	6.5	83	3.5
KI 280 S	75	100	123	1485	94.7	0.9	2.3	1.5	2.0	6.5	86	3.5
KI 280 M	90	120	147	1485	95.0	0.9	2.3	1.5	2.0	6.0	86	3.5

Performance Data

3 Phase TEFC/ Squirrel Cage Motor, 6 Pole – 1000 rpm Synchronous Speed

Eff2

Frame	Rated Power		Rated Current	Speed	% Eff.	Power Factor	Max. Torque	Min. Torque	Locked Torque	Locked Current	Noise Level At No Load	Vib. Speed
					(FL)	(FL)	Rated Torque	Rated Torque	Rated Torque	Rated Current	dB (A)	mm/s
	kW	HP	Amp	RPM			$\frac{T_{max}}{T_n}$	$\frac{T_{min}}{T_n}$	$\frac{T_{st}}{T_n}$	$\frac{I_{st}}{I_n}$		
KI 90S	0.75	1	2.1	925	72.5	0.71	2.1	1.5	2.1	4.5	57	1.8
KI 90L	1.1	1.5	3.0	925	74.5	0.71	2.1	1.3	2.1	4.5	57	1.8
KI 100L	1.5	2	3.7	950	78.0	0.74	2.1	1.3	2.1	4.5	61	1.8
KI 112M	2.2	3	5.2	950	81.0	0.75	2.1	1.3	2.1	5.0	65	1.8
KI 132M*	3.7	5	8.0	970	85.5	0.76	2.1	1.3	2.1	5.5	69	1.8
KI 132M	5.5	7.5	11.5	970	86.5	0.77	2.1	1.3	2.1	6.0	69	1.8
KI 160M	7.5	10	15.5	970	88.5	0.78	2.1	1.3	1.9	5.0	73	2.8
KI 160L	11	15	22.0	970	89.0	0.80	2.1	1.2	1.9	5.5	73	2.8
KI 180L	15	20	28.0	980	90.0	0.83	2.1	1.2	1.9	5.5	73	2.8
KI 200L	18.5	25	33.0	980	91.5	0.86	2.1	1.2	1.9	6.0	76	2.8
KI 200L	22	30	39.0	980	92.0	0.86	2.1	1.2	1.9	6.5	76	2.8
KI 225M	30	40	52.5	985	93.5	0.86	2.1	1.2	1.8	5.0	76	2.8
KI 250M	37	50	65.0	985	93.5	0.86	2.2	1.2	1.8	6.0	78	3.5
KI 280S	45	60	77.0	985	93.5	0.88	2.2	1.2	1.8	6.0	80	3.5
KI 280M	55	75	94.0	985	93.8	0.88	2.2	1.2	1.8	6.0	80	3.5

3 Phase TEFC/ Squirrel Cage Motor, 8Pole – 750 rpm Synchronous Speed

Eff2

Frame	Rated Power		Rated Current	Speed	% Eff.	Power Factor	Max. Torque	Min. Torque	Locked Torque	Locked Current	Noise Level At No Load	Vib. Speed
					(FL)	(FL)	Rated Torque	Rated Torque	Rated Torque	Rated Current	dB (A)	mm/s
	kW	HP	Amp	RPM			$\frac{T_{max}}{T_n}$	$\frac{T_{min}}{T_n}$	$\frac{T_{st}}{T_n}$	$\frac{I_{st}}{I_n}$		
KI 100L	1.1	1.5	3.2	700	73.0	0.69	2.0	1.2	1.8	4.0	59	1.8
KI 112M	1.5	2	4.2	710	75.0	0.69	2.0	1.2	1.8	4.0	61	1.8
KI 132S	2.2	3	5.6	715	78.0	0.71	2.0	1.2	1.8	5.0	64	1.8
KI 160M	3.7	5	8.8	720	81.0	0.73	2.0	1.2	1.9	5.5	68	2.8
KI 160M	5.5	7.5	12.5	720	83.0	0.74	2.0	1.2	2.0	5.0	68	2.8
KI 160L	7.5	10	16.5	720	85.5	0.75	2.0	1.2	2.0	6.0	68	2.8
KI 180L	11	15	23.0	730	87.5	0.76	2.0	1.1	2.0	5.5	70	2.8
KI 200L	15	20	32.0	730	88.0	0.76	2.0	1.1	2.0	5.0	73	2.8
KI 225S	18.5	25	38.0	735	90.0	0.76	2.0	1.1	1.9	5.0	73	2.8
KI 225M	22	30	44.0	735	90.5	0.78	2.0	1.1	1.9	5.0	73	2.8
KI 250M	30	40	60.8	735	91.0	0.80	2.2	1.2	1.9	6.0	75	3.5
KI 280S	37	50	73.9	740	91.5	0.80	2.2	1.2	1.9	6.0	76	3.5
KI 280M	45	60	89.4	740	92.0	0.80	2.2	1.2	1.9	6.0	76	3.5

Note: Performance figures declared are at rated supply condition and are subject to IS:325 tolerance.
*Motor Provided also with Mounting holes suitable for 132S frame.

Dimensional Drawings

B3-Foot mounting

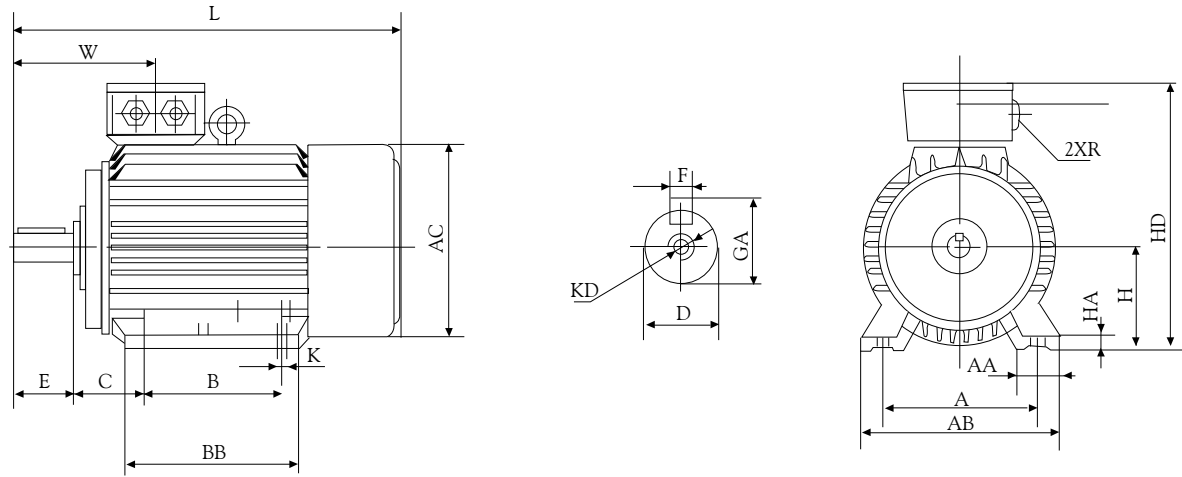

Frame	Pole	A	AA	AB	AC	B	BB	C	H	HA	HD	K	L	W	R	D	E	F	GA	KD
KI 80	2,4	125	34	165	156	100	130	50	80	10	220	10	290	112	M20X1.5	19	40	6	21.5	M6
KI 90S	2,4,6	140	36	180	176	100	130	56	90	12	250	10	325	130	M25X1.5	24	50	8	27	M8
KI 90L	2,4,6	140	36	180	176	125	155	56	90	12	250	10	345	130	M25X1.5	24	50	8	27	M8
KI 100L	2,4,6,8	160	40	205	196	140	176	63	100	15	275	12	385	138	M25X1.5	28	60	8	31	M10
KI 112M	2,4,6,8	190	50	245	220	140	180	70	112	15	300	12	405	147	M25X1.5	28	60	8	31	M10
KI 132S	2,4,6,8	216	60	280	260	140	200	89	132	18	345	12	475	179	M32X1.5	38	80	10	41	M12
KI 132M	2,4,6,8	216	60	280	260	178	238	89	132	18	345	12	515	179	M32X1.5	38	80	10	41	M12
KI 160M	2,4,6,8	254	70	335	315	210	266	108	160	20	420	15	620	258	M40X1.5	42	110	12	45	M16
KI 160L	2,4,6,8	254	70	335	315	254	310	108	160	20	420	15	660	258	M40X1.5	42	110	12	45	M16
KI 180M	2,4,6,8	279	70	355	356	241	307	121	180	23	460	15	670	271	M40X1.5	48	110	14	51.5	M16
KI 180L	2,4,6,8	279	70	355	356	279	345	121	180	23	460	15	710	271	M40X1.5	48	110	14	51.5	M16
KI 200L	2,4,6,8	318	70	395	400	305	375	133	200	25	510	19	770	296	M50X1.5	55	110	16	59	M20
KI 225S	4,6,8	356	75	435	446	286	368	149	225	28	560	19	805	329	M50X1.5	60	140	18	64	M20
KI 225M	2	356	75	435	446	311	393	149	225	28	560	19	800	299	M50X1.5	55	110	16	59	M20
	4,6,8	356	75	435	446	311	393	149	225	28	560	19	830	329	M50X1.5	60	140	18	64	M20
KI 250M	2	406	80	490	490	349	455	168	250	30	620	24	910	354	M63X1.5	60	140	18	64	M20
	4,6,8	406	80	490	490	349	455	168	250	30	620	24	910	354	M63X1.5	65	140	18	69	M20
KI 280S	2	457	85	550	550	368	480	190	280	35	670	24	960	356	M63X1.5	65	140	18	69	M20
	4,6,8	457	85	550	550	368	480	190	280	35	670	24	960	356	M63X1.5	75	140	20	79.5	M20
KI280M	2	457	85	550	550	419	530	190	280	35	670	24	1015	356	M63X1.5	65	140	18	69	M20
	4,6,8	457	85	550	550	419	530	190	280	35	670	24	1015	356	M63X1.5	75	140	20	79.5	M20

TOLERANCE

Shaft diameter ≤ 28mm = j6
32-48 mm = k6
>48 mm = m6

Dimensional Drawings

B3/ B5-Foot/ Flange mounting

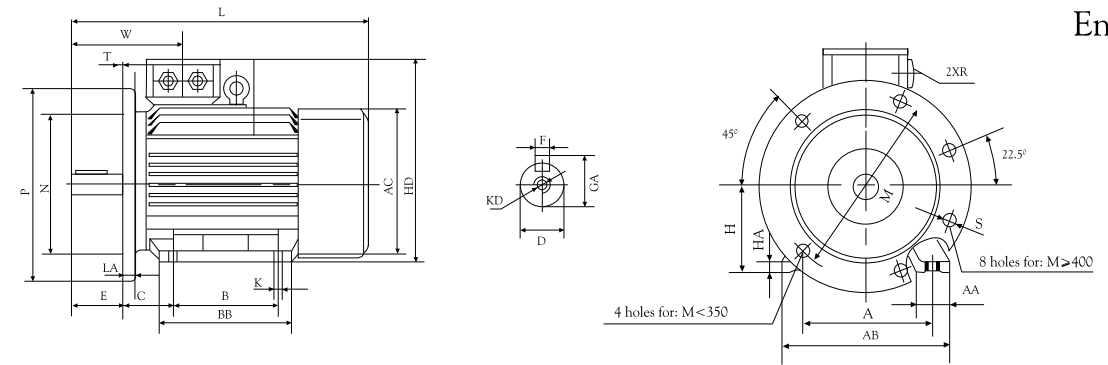

Frame	Pole	A	AA	AB	AC	B	BB	C	H	HA	HD	K	L	W
KI 80	2,4	125	34	165	156	100	130	50	80	10	220	10	290	112
KI 90S	2,4,6	140	36	180	176	100	130	56	90	12	250	10	325	130
KI 90L	2,4,6	140	36	180	176	125	155	56	90	12	250	10	345	130
KI 100L	2,4,6,8	160	40	205	196	140	176	63	100	15	275	12	385	138
KI 112M	2,4,6,8	190	50	245	220	140	180	70	112	15	300	12	405	147
KI 132S	2,4,6,8	216	60	280	260	140	200	89	132	18	345	12	475	179
KI 132M	2,4,6,8	216	60	280	260	178	238	89	132	18	345	12	515	179
KI 160M	2,4,6,8	254	70	335	315	210	266	108	160	20	420	15	620	258
KI 160L	2,4,6,8	254	70	335	315	254	310	108	160	20	420	15	660	258
KI 180M	2,4,6,8	279	70	355	356	241	307	121	180	23	460	15	670	271
KI 180L	2,4,6,8	279	70	355	356	279	345	121	180	23	460	15	710	271
KI 200L	2,4,6,8	318	70	395	400	305	375	133	200	25	510	19	770	296
KI 225S	4,6,8	356	75	435	446	286	368	149	225	28	560	19	805	329
KI 225M	2	356	75	435	446	311	393	149	225	28	560	19	800	299
	4,6,8	356	75	435	446	311	393	149	225	28	560	19	830	329
KI 250M	2	406	80	490	490	349	455	168	250	30	620	24	910	354
	4,6,8	406	80	490	490	349	455	168	250	30	620	24	910	354
KI 280S	2	457	85	550	550	368	480	190	280	35	670	24	960	356
KI 280M	4,6,8	457	85	550	550	368	480	190	280	35	670	24	960	356
	2	457	85	550	550	419	530	190	280	35	670	24	1015	356
	4,6,8	457	85	550	550	419	530	190	280	35	670	24	1015	356

Frame	Pole	R	LA	M	N	P	S	T	D	E	F	GA	KD
KI 80	2,4	M20X1.5	12	165	130	200	12	3.5	19	40	6	21.5	M6
KI 90S	2,4,6	M25X1.5	12	165	130	200	12	3.5	24	50	8	27	M8
KI 90L	2,4,6	M25X1.5	12	165	130	200	12	3.5	24	50	8	27	M8
KI 100L	2,4,6,8	M25X1.5	14	215	180	250	15	4	28	60	8	31	M10
KI 112M	2,4,6,8	M25X1.5	14	215	180	250	15	4	28	60	8	31	M10
KI 132S	2,4,6,8	M32X1.5	14	265	230	300	15	4	38	80	10	41	M12
KI 132M	2,4,6,8	M32X1.5	14	265	230	300	15	4	38	80	10	41	M12
KI 160M	2,4,6,8	M40X1.5	15	300	250	350	19	5	42	110	12	45	M16
KI 160L	2,4,6,8	M40X1.5	15	300	250	350	19	5	42	110	12	45	M16
KI 180M	2,4,6,8	M40X1.5	15	300	250	350	19	5	48	110	14	51.5	M16
KI 180L	2,4,6,8	M40X1.5	15	300	250	350	19	5	48	110	14	51.5	M16
KI 200L	2,4,6,8	M50X1.5	17	350	300	400	19	5	55	110	16	59	M20
KI 225S	4,6,8	M50X1.5	20	400	350	450	19	5	60	140	18	64	M20
KI 225M	2	M50X1.5	20	400	350	450	19	5	55	110	16	59	M20
	4,6,8	M50X1.5	20	400	350	450	19	5	60	140	18	64	M20
KI250M	2	M63X1.5	20	500	450	550	19	5	60	140	18	64	M20
	4,6,8	M63X1.5	20	500	450	550	19	5	65	140	18	69	M20
KI280S	2	M63X1.5	22	500	450	550	19	5	65	140	18	69	M20
	4,6,8	M63X1.5	22	500	450	550	19	5	75	140	20	79.5	M20
KI280M	2	M63X1.5	22	500	450	550	19	5	65	140	18	69	M20
	4,6,8	M63X1.5	22	500	450	550	19	5	75	140	20	79.5	M20

TOLERANCE

Shaft diameter ≤ 28mm = j6
32-48 mm = k6
>48 mm = m6

Dimensional Drawings

B5 -Flange mounting

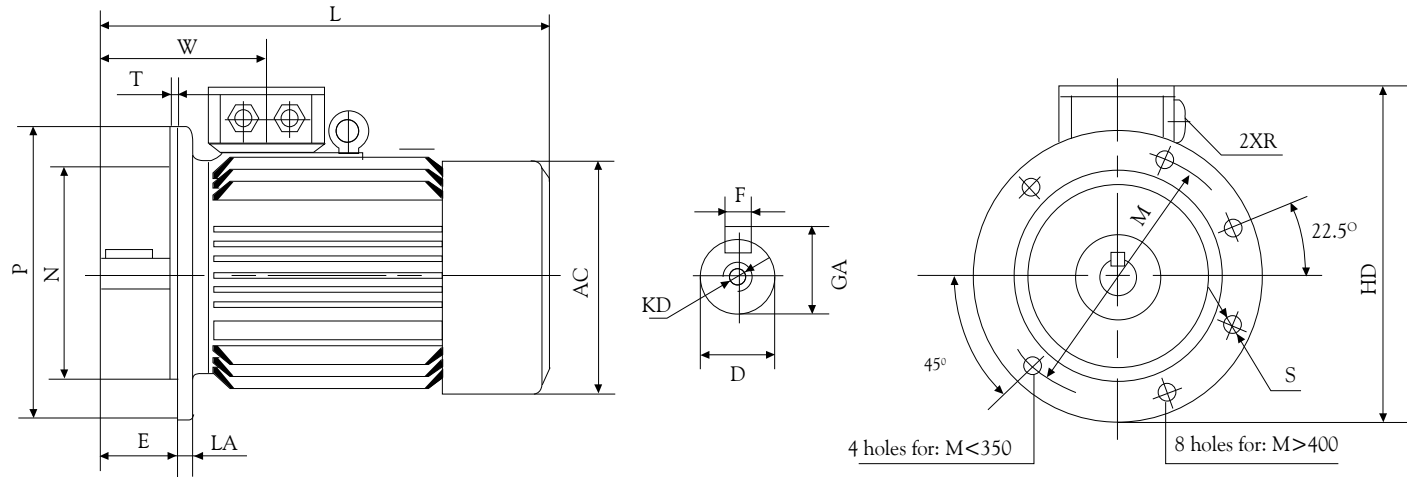

Frame	Pole	AC	HD	L	W	R	LA	M	N	P	S	T	D	E	F	GA	KD
KI 80	2,4	156	240	290	112	M20X1.5	12	165	130	200	12	3.5	19	40	6	21.5	M6
KI 90S	2,4,6	176	260	325	130	M25X1.5	12	165	130	200	12	3.5	24	50	8	27	M8
KI 90L	2,4,6	176	260	345	130	M25X1.5	12	165	130	200	12	3.5	24	50	8	27	M8
KI 100L	2,4,6	196	300	385	138	M25X1.5	14	215	180	250	15	4	28	60	8	31	M10
KI 112M	2,4,6,8	220	310	405	147	M25X1.5	14	215	180	250	15	4	28	60	8	31	M10
KI 132S	2,4,6,8	260	360	475	179	M32X1.5	14	265	230	300	15	4	38	80	10	41	M12
KI 132M	2,4,6	260	360	515	179	M32X1.5	14	265	230	300	15	4	38	80	10	41	M12
KI 160M	2,4,6,8	315	435	620	258	M40X1.5	15	300	250	350	19	5	42	110	12	45	M16
KI 160L	2,4,6,8	315	435	660	258	M40X1.5	15	300	250	350	19	5	42	110	12	45	M16
KI 180M	2,4,6,8	356	455	670	271	M40X1.5	15	300	250	350	19	5	48	110	14	51.5	M16
KI 180L	2,4,6,8	356	455	710	271	M40X1.5	15	300	250	350	19	5	48	110	14	51.5	M16
KI 200L	2,4,6,8	400	510	770	296	M50X1.5	17	350	300	400	19	5	55	110	16	59	M20
KI 225S	4,6,8	446	560	805	329	M50X1.5	20	400	350	450	19	5	60	140	18	64	M20
KI 225M	2	446	560	800	299	M50X1.5	20	400	350	450	19	5	55	110	16	59	M20
	4,6,8	446	560	830	329	M50X1.5	20	400	350	450	19	5	60	140	18	64	M20
KI 250M	2	490	645	910	354	M63X1.5	20	500	450	550	19	5	60	140	18	64	M20
	4,6,8	490	645	910	354	M63X1.5	20	500	450	550	19	5	65	140	18	69	M20
KI 280S	2	550	665	960	356	M63X1.5	22	500	450	550	19	5	65	140	18	69	M20
	4,6,8	550	665	960	356	M63X1.5	22	500	450	550	19	5	75	140	20	79.5	M20
KI 280M	2	550	665	1015	356	M63X1.5	22	500	450	550	19	5	65	140	18	69	M20
	4,6,8	550	665	1015	356	M63X1.5	22	500	450	550	19	5	75	140	20	79.5	M20

TOLERANCE

Shaft diameter ≤ 28mm = j6
32-48 mm = k6
>48 mm = m6

Dimensional Drawings

B3/B14-Foot/Face mounting

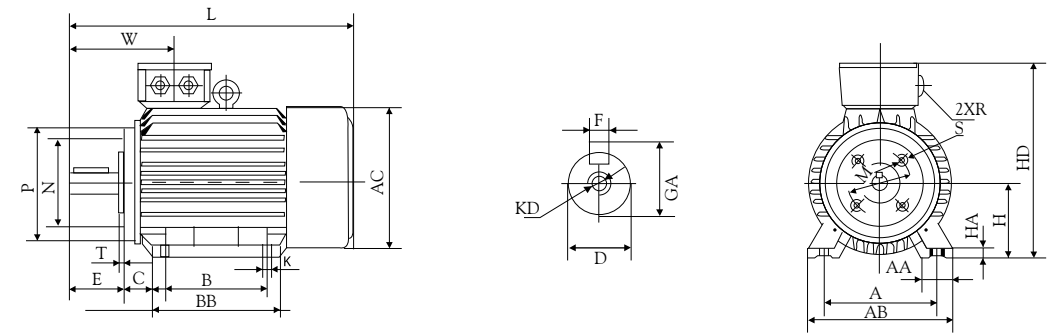

Frame	Pole	A	AA	AB	AC	B	BB	C	H	HA	HD	K	L	W
KI 80	2,4	125	34	165	156	100	130	50	80	13	220	10	290	112
KI 90S	2,4,6	140	36	180	176	100	130	56	90	13	245	10	325	130
KI 90L	2,4,6	140	36	180	176	125	155	56	90	13	245	10	345	130
KI 100L	2,4,6	160	40	205	196	140	176	63	100	15	270	12	380	138
KI 112M	2,4,6,8	190	50	245	220	140	180	70	112	18	295	12	405	147

Frame	R	M	N	P	S	T	D	E	F	GA	KD
KI 80	M20X1.5	100	80	120	M6	3.0	19	40	6	21.5	M6
KI 90S	M25X1.5	115	95	140	M8	3.5	24	50	8	27	M8
KI 90L	M25X1.5	115	95	140	M8	3.5	24	50	8	27	M8
KI 100L	M25X1.5	130	110	160	M8	3.5	28	60	8	31	M10
KI 112M	M25X1.5	130	110	160	M8	3.5	28	60	8	31	M10

TOLERANCE

Shaft diameter ≤ 28mm = j6
32-48 mm = k6
>48 mm = m6

B14-Face mounting

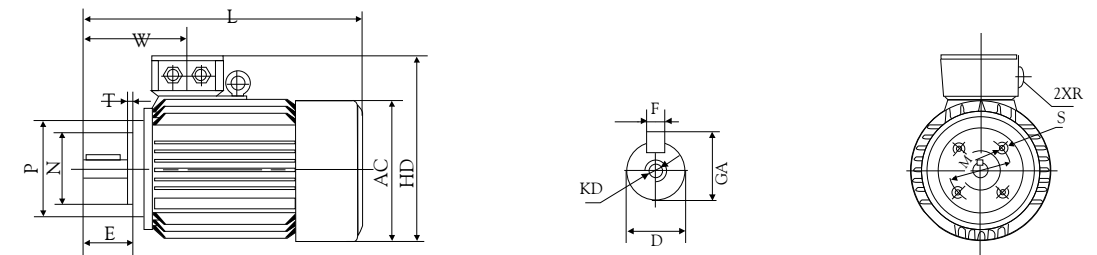

Frame	Pole	AC	HD	L	W	R	M	N	P	S	T	D	E	F	GA	KD
KI 80	2,4	156	240	290	112	M20X1.5	100	80	120	M6	3.0	19	40	6	21.5	M6
KI 90S	2,4,6	176	255	325	130	M25X1.5	115	95	140	M8	3.5	24	50	8	27	M8
KI 90L	2,4,6	176	255	345	130	M25X1.5	115	95	140	M8	3.5	24	50	8	27	M8
KI 100L	2,4,6	196	295	380	138	M25X1.5	130	110	160	M8	3.5	28	60	8	31	M10
KI 112M	2,4,6,8	220	295	405	147	M25X1.5	130	110	160	M8	3.5	28	60	8	31	M10

TOLERANCE

Shaft diameter ≤ 28mm = j6
32-48 mm = k6
>48 mm = m6

Inhouse Testing Facility



Regional Offices

AHMEDABAD

11, Mill Officers Colony, Behind La Gajjar
Chambers, Ashram Road, AHMEDABAD 380 009
Phone : (079) 26580376, 26583615
Fax : (079) 26583786

BANGALORE

No. 5, Lakshmi Complex, IInd Floor, 10th Cross,
RMV Extension, C.V. Raman Road,
BANGALORE 560 080
Phone : (080) 23619914, 23619915
Fax : (080) 23610095

BHUBANESWAR

Uttam Tower, Plot No. 969 (Part A), Block B,
1st Floor, Ashok Nagar, Unit II,
BHUBANESWAR 751009
Phone : (0674) 2535371, 2536421
Fax : (0674) 2534965

CHENNAI

Raj Paris Trimeni Tower, 2nd Flr, 147,
G N Chetty Road
T. Nagar, CHENNAI 600 017
Phone : (044) 28156546, 28156547
Fax : (044) 28156549

DEWAS

Ujjain Road, Dewas 455 001 (M.P.)
Phone: (07272) 227327, 227354
Fax: (07272) 228747

JAIPUR

Flat No. 102, Riddhi Siddhi Apartment,
Ahinsa Circle, C Scheme JAIPUR 302 001.
Phone: (0141) 2361434, 2361412
Fax: (0141) 2375670

KOCHI

Veejay Towers, Salim Rajan Road,
Gandhinagar, Ernakulam KOCHI 682 017
Phone: (0484) 2206651, 2206652
Fax: (0484) 2206653

KOLKATA

2nd Floor, Space No. 1, 8, Camac Street,
'Shantiniketan', KOLKATA 700 017
Phone: (033) 22827225, 22820891,
Fax : (033) 22829915

LUCKNOW

B -1/7, Sector A, Aliganj, LUCKNOW 226 024
Phone: (0522) 2326367, 2326374
Fax: (0522) 2326365

MUMBAI

10, Corporate Park, Sion Trombay Road,
Swastik Mills Compound,
Chembur, MUMBAI 400 071
Phone : (022) 25287558
Fax : (022) 25289329

NAGPUR

Plot No. 19, Flat No. 7, "Sagar Palace"
East High Court Road, Behind "Bal Jagat",
Laxmi Nagar, NAGPUR 440 022
Telefax: (0712) 2243001

NEW DELHI

Jeevan Tara Building, 5, Parliament Street,
NEW DELHI 110 001
Phone : (011) 41501055-62
Fax : (011) 23342002

PUNE

Prapat Apartment, 108/B, Tulshibagwale Colony,
Sahakar Nagar No. 02, Parvati PUNE 411 009
Phone : (020) 2422 8712 - 14
Fax : (020) 24224888

RANCHI

1st, Floor Mahabir Tower,
Opp. Gel Church Complex
Main Road, RANCHI- 1
Cell: 09430140494

SECUNDERABAD

Post Box No. 1580, 403, Jade Arcade,
126, M. G. Road, Paradise Circle, SECUNDERABAD
Phone : (040) 27894595, 27894596,
Fax : (040) 27894598

Other Contact Details

Guwahati-09864264877
Ludhiana-09711191415
Raipur-09425048744



Enriching Lives

KIRLOSKAR BROTHERS LIMITED

REGD. CORPORATE OFFICE & EXPORT DIVISION:

Udyog Bhavan, Tilak Road, Pune- 411 002 (INDIA)
Phone: +91 20 2444 0770 Fax: +91 20 2444 4198 Email: kblin@kbl.co.in

MARKETING & WORKS:

Ujjain Road, Dewas - 455 001 (M.P.) Phone: (07272) 227401 /2 /5 /9
Fax: (07272) 228747 - E-mail: mkt@dws.kbl.co.in



As we are constantly endeavouring to improve the performance of our products/equipment, we reserve the right to make alterations from time to time, and so, our products/equipment may differ from that detailed in this publication. For latest information, you may get in touch with us.