

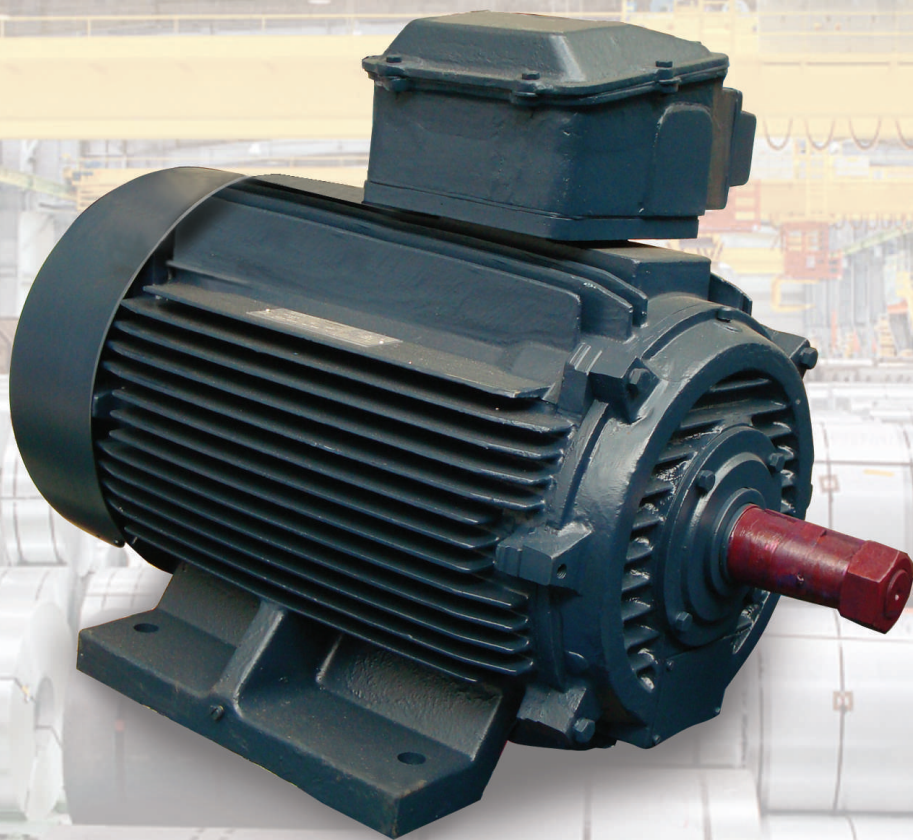

KD

## Squirrel Cage Crane Duty Induction Motors



*Motors for the Long Run!*

## Introduction

MARATHON Electric presents KD series TEFC squirrel cage motors specifically designed for DOL operated Crane duty / intermittent duty application. The motors are designed to take care of the high electrical and mechanical stresses arising due to frequent starts - stops associated with intermittent duty application. The motors are compact providing high output for a given frame size and have low inertia. These salient features make them most suitable for EOT Cranes.

## Range

Frame size KD71-KD355L

## Output

Refer to Table 7

## Standards & Specification

KD series motors generally conform to the following standards :

IS:325 /IEC:60034-1	Three-phase induction motors
IS:1231 /IS:2223	Dimensions
IS:4691	Degree of protection

The motors can also be offered as per IPSS specification.



## Supply & Operating Conditions

These motors can be wound for any voltages from 200 volts to 690 volts and for either 50Hz or 60 Hz frequency. Standard KD motors are available for supply voltage of 415V and frequency of 50Hz.

The supply voltage is assumed to be sinusoidal and balanced as defined in IS:325.

The motors are suitable for operation with variation in supply and site conditions as indicated in Table 1.

Table 1

Ambient	Altitude	Voltage Variation	Frequency Variation	Combined Variation
45°C	≤ 1000m	±10%	±5%	10%

In the event of sustained operation at extreme limits of supply variation, the temperature rise may exceed by 10°C. For other site conditions motor output should be adjusted as per Tables 2 & 3.

Table -2  
Deration for High Ambient temp.

Ambient temp.	45°C	50°C	55°C	60°C	65°C
Class 'B' Temp. limit	100%	95%	90%	85%	80%
Class 'F' Temp. limit	100%	100%	100%	95%	85%

Table - 3  
Deration for Altitude

Altitude	1500 m	2000 m	2500 m	3000 m	3500 m
Class 'B' Temp. Limit	95%	91%	87%	83%	70%
Class 'F' Temp. Limit	100%	100%	95%	90%	85%

### Mounting

Standard KD motors are supplied with horizontal foot mounting ( IMB3 ) . However, motors can be supplied with other options like flange (IMB5/IMV1/IMV3) mounting / foot-cum-flange (IMB35)/face mounting (IMB14).

### Insulation and Temperature rise

KD motors are provided with Class 'F' insulation and will operate satisfactorily in an ambient temperature range -20°C to 45°C with class 'B' temperature rise (75°C by resistance method) at nominal voltage / frequency and for altitude upto 1000m above mean sea level. Class 'H' insulation may be supplied on request.

### Duties

KD motors are generally used for intermittent duties like S2 /S3 / S4 & S5 associated with cyclic duration factor (CDF) and no. of starts per hour, as defined in IS 12824.

The Cyclic Duration Factor is defined as follows :

$$\% \text{ CDF} = \frac{\text{Period energised}}{\text{Duration of complete duty cycle}} \times 100$$

The descriptive details of various duties associated with intermittent /crane duty application experienced by KD motors are as follows :

#### S2 Duty ( Shot time Duty )

Operation at constant load during a given time, less than that required to reach thermal equilibrium, followed by a rest and de-energized period of sufficient duration to re-establish machine temperatures within 2°C of the coolant ( see Fig. 1).

The recommended values for the short-time duty are 10, 30,60 and 90 minutes

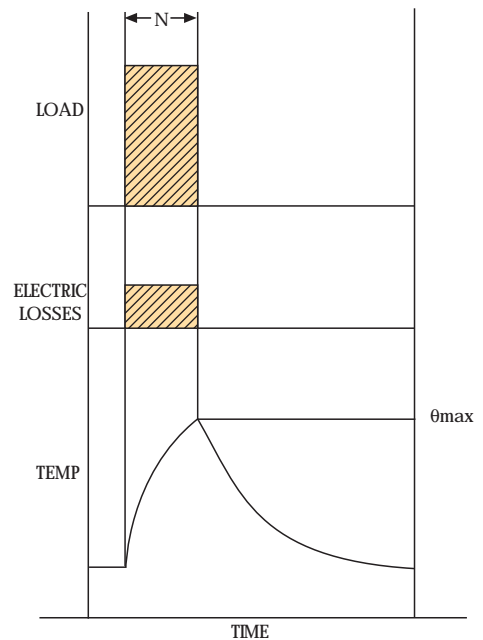

N = Operation at constant load  
 $\theta_{max}$  = Maximum temperature attained during the duty cycle

Figure 1 – Short time duty – S2

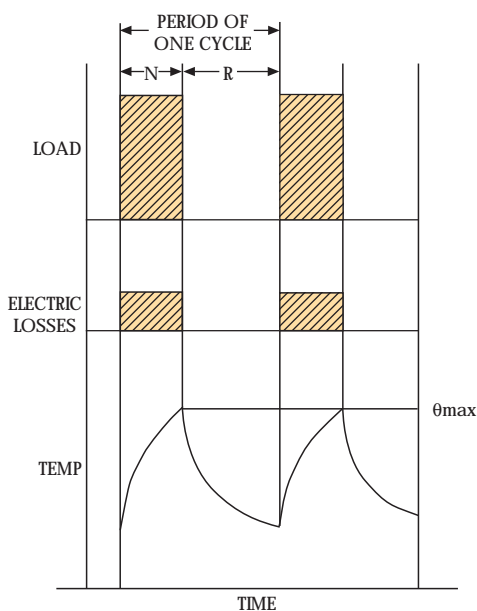

N = Operation at constant load  
 R = At rest and de-gized  
 $\theta_{max}$  = Maximum temperature attained during the duty cycle

$$\text{Cyclic duration factor} = \frac{N}{N + R} \times 100\%$$

Figure 2 – Intermittent periodic duty – S3

#### S3 Duty ( Intermittent Duty )

A sequence of identical duty cycles, each including a period of operation at constant load and a rest and de-energized period. These periods being too short to attain thermal equilibrium during one duty cycle ( see Fig.2). In this duty, the cycle is such that the starting current does not significantly affect the temperature rise for this duty cycle.

Unless otherwise specified the periodic duty is applicable for 10 minutes duration. The S3 duty generally is associated with 6 starts per hour.

## S4 Duty (Intermittent Duty with Starting )

A sequence of identical duty cycles, each cycle including a significant period of starting, a period of operation at constant load and a rest and de-energized period. These periods being too short to attain thermal equilibrium during one duty cycle (see Fig.3).

Motor is stopped either naturally or by means of mechanical brake so that there is no cause of extra heat.

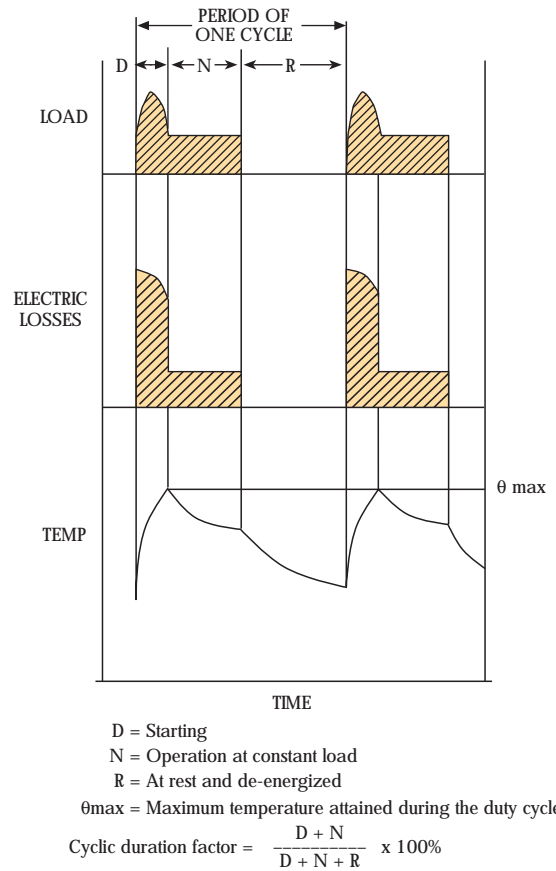

Figure 3 – Intermittent periodic duty with starting – S4

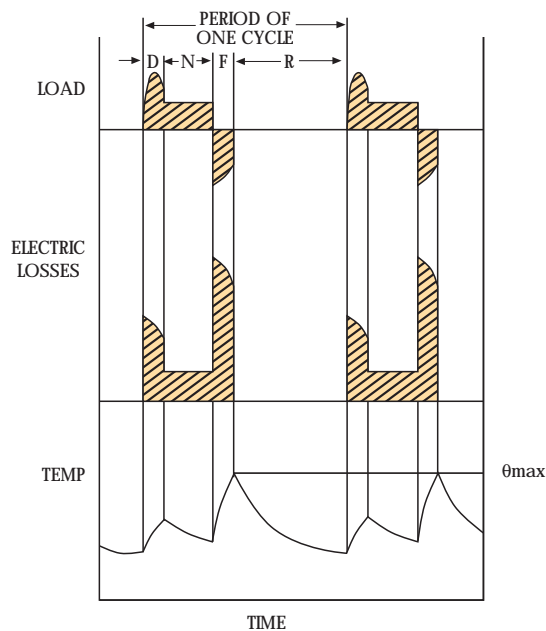

Figure 4 – Intermittent periodic duty with Electric Braking – S5

## S5 Duty (Intermittent Duty with Electrical Braking )

A sequence of identical duty cycles, each cycle consisting of a period of starting, a period of operation at constant load, a period of rapid electric braking and rest and de-energized period. The operating and rest and de-energized periods being too short to attain thermal equilibrium during one duty cycle (see Fig.4).

While specifying duty cycle for S3 duty % CDF is to be specified and for S4/S5 duties – % CDF and no. of starts per hour, is to be specified.

## Constructional Features

### Frame

The stator frames in general are made of rugged cast iron with integral cast feet in case of foot mounted motors. Maximum cooling surface is obtained by quadrangular disposition of cooling ribs. (See Fig. 5)

### End bracket

Ribbed end brackets are provided from frame KD160 upwards. For frame sizes upto KD225S, single piece end bracket is eliminating outer bearing cap.

For frame sizes KD200L and above, unique feature of grease relief arrangement facilitating on-line re-greasing is provided. (See Fig. 6)

## Shaft

Standard KD motors have single cylindrical shaft extension. However, double cylindrical shaft extension or tapered shaft extension ( single / double ) can be offered on request.

## Terminal box

The terminal box position of all the motors are on RHS when viewed from the driving end except for KD71 frame & KD112M frames. The terminal box position for these frames are on TOP only.

Terminal box for all the motors can be rotated in steps of 90° through 360° – there by providing four alternative direction of cable entry.

Cable sizes for standard terminal box arrangement are given in Table 4 .

Table - 4  
FRAME SIZE STUD SIZE MAX. CABLE SIZE DOWELL'S CAT. NO

Frame size	Stud size	Max. Cable size	Dowell's Cat. No.
71 – 90	M5	1 NO. 3C X 4 mm	CUS/06
100 – 132	M6	1 NO. 3C X 6 mm	CUS/07
	M6	1 NO. 3C X 35 mm	CUS/11
160 - 180	M6	1 NO. 3C X 50 mm	CUS/13
200 - 225	M12	1 NO. 3C X 70 mm	CUS/18
250 - 280	M12	1 NO. 3C X 185 mm	CUS/25, 20
	M12	2 NO. 3C X 185 mm	CUS/29
315	M12	1 NO. 3C X 300 mm	CUS/29
	M12	1 NO. 3C X 300 mm	CUS/29
355	M12/M16	2 NOS. 3C X 300 mm	CUS/27

## Bearings

Metric size ball / roller bearings with C3 clearance are used in horizontal foot mounted motors. For frame sizes upto KD315L, ball bearings are used at both ends whereas for frame size KD355 – roller / ball bearings are used on DE/NDE side respectively. Bearing size for motors with single shaft extension are as per Table 5. Double sealed bearings are used upto frame 180. These bearings are prelubricated and does not allow relubrication. Grease used for motors of frame 200 okward is Alithex 20 or equivalent [Lithium based grad 2]

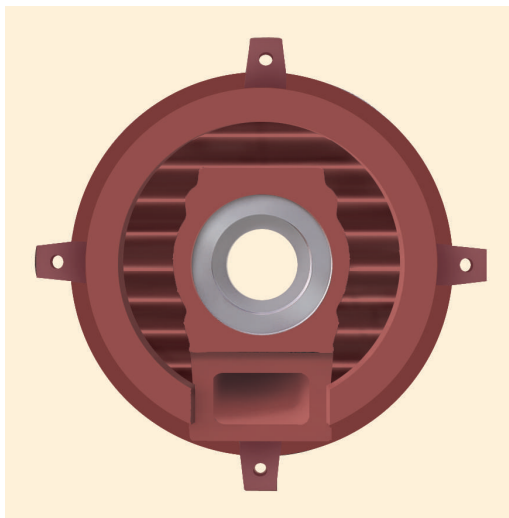

Fig. 5

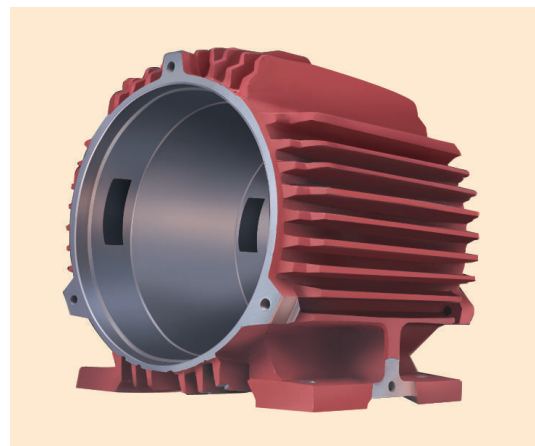

Fig. 6

Table – 5

## Bearing Data

FRAME SIZE	POLES	HORIZONTAL MOUNTING		VERTICAL MOUNTING	
		DRIVE END	NON-DRIVE END	DRIVE END	NON-DRIVE END
71	ALL	6203ZZ C3	6203ZZ C3	6203ZZ C3	6203ZZ C3
80	ALL	6204ZZ C3	6204ZZ C3	6204ZZ C3	6204ZZ C3
90	ALL	6205ZZ C3	6204ZZ C3	6205ZZ C3	6204ZZ C3
100	ALL	6206ZZ C3	6205ZZ C3	6206ZZ C3	6205ZZ C3
112	ALL	6206ZZ C3	6205ZZ C3	6206ZZ C3	6205ZZ C3
132	ALL	6208ZZ C3	6207ZZ C3	6208ZZ C3	6207ZZ C3
160	ALL	6309ZZ C3	6209ZZ C3	6309ZZ C3	6209ZZ C3
180	ALL	6310ZZ C3	6210ZZ C3	6310ZZ C3	6210ZZ C3
200	ALL	6312 C3	6310ZZ C3	6312 C3	6310ZZ C3
225 S	ALL	6313 C3	6312 C3	6313 C3	6312 C3
225 M	ALL	6313 C3	6313 C3	6313 C3	6313 C3
250	ALL	6314 C3	6313 C3	6314 C3	6313 C3
280	ALL	6317 C3	6314 C3	6317 C3	6317 C3
315 S/M1	4,6,8	6319 C3	6316 C3	6319 C3	6316 C3
315 M2/L	4,6,8	6319 C3	6319 C3	6319 C3	6319 C3
355 S/M&L	4,6,8	N/NU321	6321 C3	N/NU321	6321 C3

### Cooling and Degree of protection

KD series motors have cooling arrangement as per IC411 (TEFC) in accordance with IS:6362. The degree of protection of standard KD series motors is IP-55 as per IS:4691. Refer to Fig. 8 for an exploded view.

Accessories (can be provided on request):

### Anti-condensation Heating

For motors remaining idle under severe cold climatic condition or under highly humid atmosphere, use of anti-condensation heating is recommended. The heating serves to maintain the average temperature inside the enclosure at a level so as to avoid condensation. The heating must be switched OFF while motor is in operation .

For motors upto 132 frame, 2 terminals of either STAR or DELTA connected winding may be connected to 1- phase, 24 volts, A.C. supply for anti-condensating heating. For higher frames, separate space heaters are provided with termination in separate terminal box.

### PTC Thermistors

This is an additional device for thermal protection . The thermistors are embedded in the winding overhang so as to sense abnormal winding temperature there by tripping the motor supply line through a relay.

Recommended reference temperature for thermistors are given below in Table 6.

Table - 6

Class of Insulation	Type of Thermistor	
	Warning	Tripping
B	PT 120	PT 140
F	PT 140	PT 160

**RTD / BTD**

These are devices to sense the winding or bearing temperature by means platinum based element. These can be provided for frames 280 & above.

**Motors with Electric brakes**

The motors can be supplied with in-built D.C. fail safe brake upto KD200L framesize. (See Fig. 7) For more details refer to works.

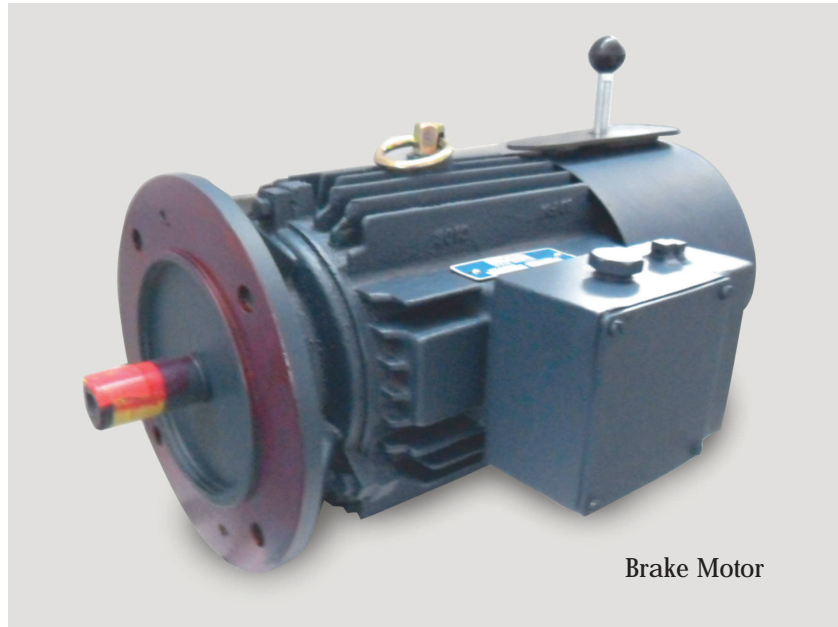

Brake Motor

Fig. 7

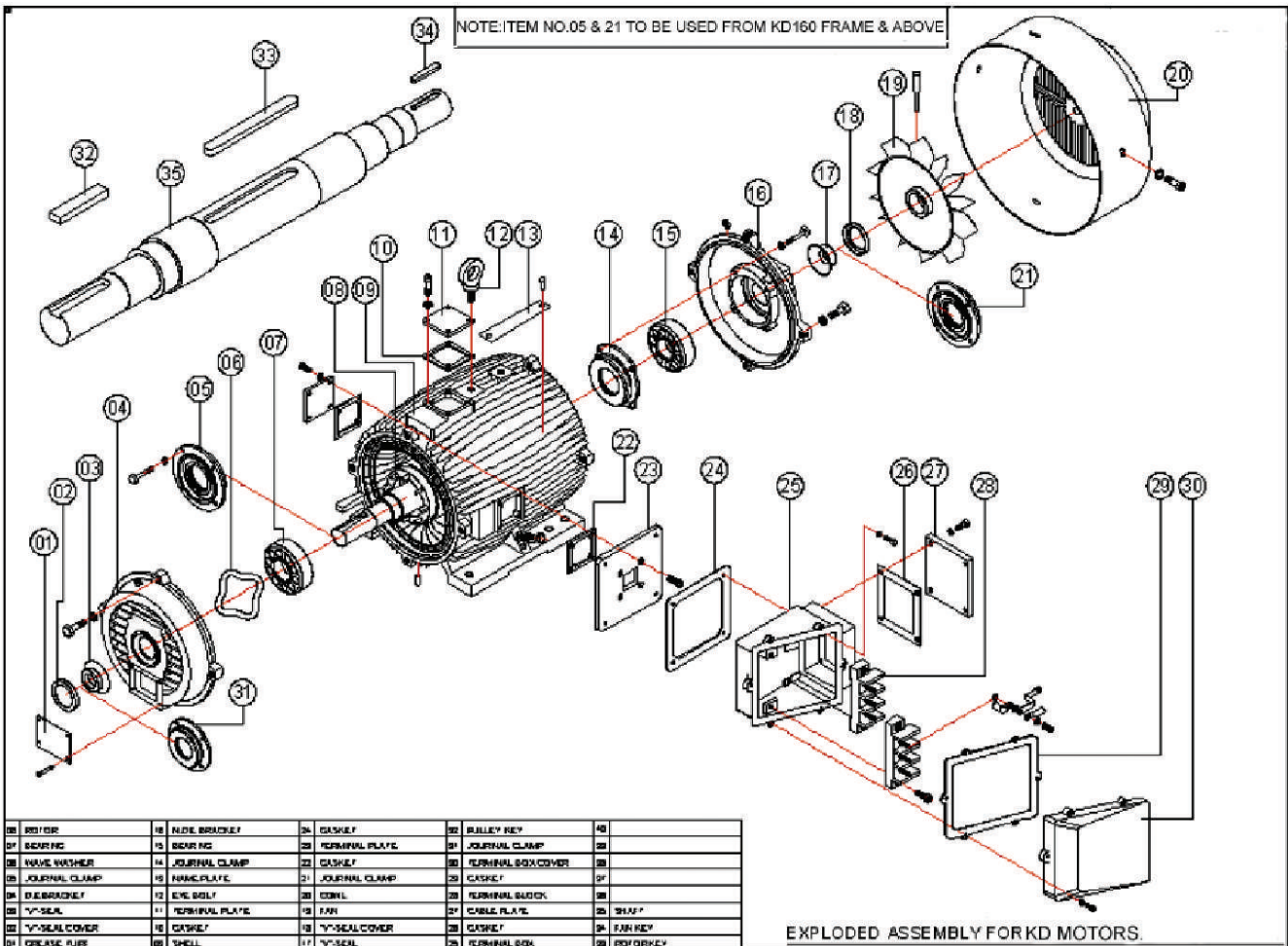
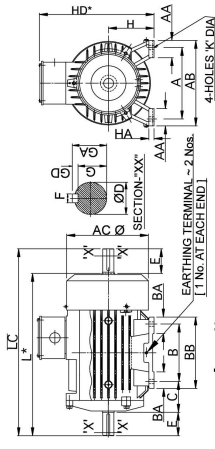
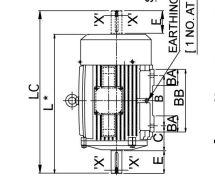

Fig. 8



Applicable for KD71



Applicable for KD80-KD132

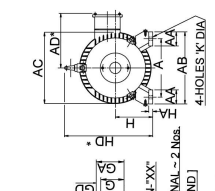

Top Terminal Applicable for KD112M

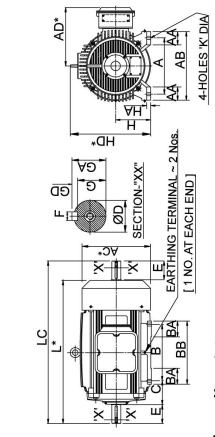
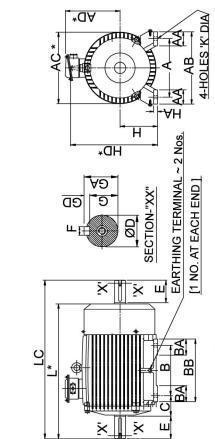

Applicable for KD160-KD250

Applicable for KD80-KD132

Top Terminal Applicable for KD112M

Applicable for KD160-KD250

Frame Size	*kw at S4, 40% CDF, 150 S/H	FIXING						SHAFT						GENERAL						Tapped Centre Hole at shaft end (As per IS:2540)		
		A	B	C	H	AB	BB	K	D	E	F	G	GA	GD	**L	IC	AA	**AC	**AD		BA	HA
KD71	0.25	112	90	45	71	134	112	7	14	30	5	16	5	255	278	27	135	-	27	8	195	T5
KD80	0.75	125	100	50	80	156	125	10	19	40	6	21.5	6	300	332	34	170	14.5	32.5	12	220	T8
KD80	1.1	125	100	50	80	156	125	10	19	40	6	21.5	6	325	362	34	170	14.5	32.5	12	220	T8
KD90S	1.5	140	100	56	90	170	155	10	24	50	8	27	7	335	386	35	190	15.0	55	12	236	T10
KD90L	2.2	140	125	56	90	170	155	10	24	50	8	27	7	375	428	35	190	15.0	55	12	236	T10
KD100L	3.7	160	140	63	100	192	170	12	28	60	8	31	7	420	489	38	220	17.5	50	12	265	T10
KD112M	5.5	190	140	70	112	222	170	12	28	60	8	31	7	470	528	45	220	18.5	50	14	285	T10
KD132S	7.5	216	140	89	132	256	222	12	38	80	10	41	8	500	582	50	265	20.5	76	14	320	T12
KD132M	9.3	216	178	89	132	256	222	12	38	80	10	41	8	500	582	50	265	20.5	76	14	320	T12
KD160M1	11	254	210	108	160	300	304	15	42	110	12	45	8	670	770	60	320	30.0	95	20	385	T16
KD160M2	15	254	210	108	160	300	304	15	42	110	12	45	8	670	770	60	320	30.0	95	20	385	T16
KD160L	18.5	254	254	108	160	300	304	15	42	110	12	45	8	710	815	60	320	30.0	95	20	385	T16
KD180M	22	279	241	121	180	344	330	15	48	110	14	51.5	9	750	850	65	345	31.5	105	25	425	T16
KD200L	30	318	305	133	200	400	356	19	55	110	16	59	10	795	916	88	390	39.5	86	35	460	T20
KD225S	37	356	286	149	225	444	375	19	60	140	18	64	11	860	994	88	390	39.5	95	35	485	T20
KD225M	45	356	311	149	225	444	375	19	60	140	18	64	11	860	1000	88	460	42.5	95	40	520	T20

\* For ratings at other duty conditions, refer to our KD motor rating chart.

**KD71-KD225M FOOT MOUNTED 4 POLE MOTOR**



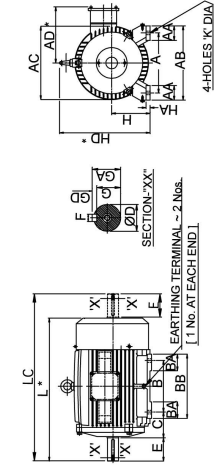

Applicable for KD80-KD132

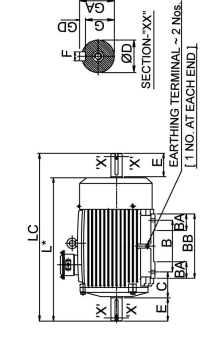

Top Terminal Applicable for KD112M

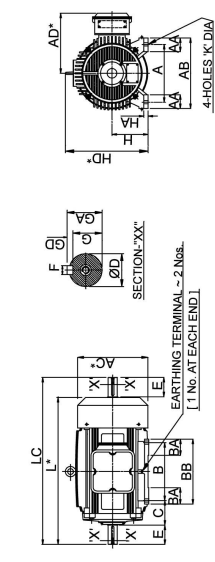

Applicable for KD160-KD250

Frame Size	*kw at S4, 40% CDF, 150 S/H	FIXING						SHAFT						GENERAL						Tapped Centre Hole at shaft end (As per IS:2540)			
		A	B	C	H	AB	BB	K	D	E	F	G	GA	GD	**L	IC	AA	**AC	**AD		BA	HA	HD
KD80	0.55	125	100	50	80	156	125	10	19	40	6	15.5	21.5	6	300	332	34	170	145	32.5	12	220	T8
KD80	0.75	125	100	50	80	156	125	10	19	40	6	15.5	21.5	6	325	362	34	170	145	32.5	12	220	T8
KD90S	1.1	140	100	56	90	170	155	10	24	50	8	20	27	7	335	386	35	190	150	55	12	236	T10
KD90L	1.5	140	125	56	90	170	155	10	24	50	8	20	27	7	375	428	35	190	150	55	12	236	T10
KD100L	2.2	160	140	63	100	192	170	12	28	60	8	24	31	7	420	489	38	220	175	50	12	265	T10
KD112M	3.7	190	140	70	112	222	170	12	28	60	8	24	31	7	470	528	45	220	185	50	14	285	T10
KD132S	5.5	216	140	89	132	256	222	12	38	80	10	33	41	8	500	582	50	265	205	76	14	320	T12
KD132M	7.5	216	178	89	132	256	222	12	38	80	10	33	41	8	500	582	50	265	205	76	14	320	T12
KD160M	9.3	254	210	108	160	300	304	15	42	110	12	37	45	8	670	770	60	320	300	95	20	385	T16
KD160L1	11	254	254	108	160	300	304	15	42	110	12	37	45	8	670	770	60	320	300	95	20	385	T16
KD160L2	15	254	254	108	160	300	304	15	42	110	12	37	45	8	710	815	60	320	300	95	20	385	T16
KD180L	18.5	279	279	121	180	344	330	15	48	110	14	42.5	51.5	9	750	850	65	345	315	90	25	425	T16
KD200L	22	318	305	133	200	400	356	19	55	110	16	49	59	10	795	916	88	390	395	86	35	460	T20
KD225M	30	356	311	149	225	444	375	19	60	140	18	53	64	11	930	1070	88	460	425	95	40	520	T20
KD250M	37	406	349	168	250	508	420	24	65	140	18	58	69	11	935	1067	108	455	425	100	42	540	T20

\* For ratings at other duty conditions, refer to our KD motor rating chart.

**KD80-KD250M FOOT MOUNTED 6 POLE MOTOR**

For GAD of higher frame sizes & 8 Pole motors - refer to works

Table -7

## Selection Chart

Ambient temp. - 45 Deg.C

Insulation - Class 'F'

Degree of protection - IP-55

Cooling - IC411

Factor of Inertia - 2 ( Load GD<sup>2</sup> = Motor GD<sup>2</sup> )

Type of start - DOL

### 4 Pole

Frame	S4-40% 150S/H	S4-60%- 150S/H	S4-40%- 300S/H	S4-60%- 300S/H
	kW			
KD71	0.55	0.55	0.55	0.55
KD80	0.75	0.75	0.75	0.75
KD80	1.1	1.1	1.1	1.1
KD90S	1.5	1.5	1.5	1.5
KD90L	2.2	2.2	2.1	2.1
KD100L	3.7	3.7	3.6	3.4
KD112M	5.5	5.5	5.3	5.1
KD132S	7.5	7.5	7.3	7.0
KD132M	9.3	9.3	9.0	8.7
KD160M1	11	10.6	10.7	10.2
KD160M2	15	14.4	14.6	14.0
KD160L	18.5	17.8	17.9	17.2
KD180M	22	21.1	21.3	20.5
KD200L	30	28.8	29.1	27.9
KD225S	37	35.5	35.9	34.5
KD225M	45	43.2	43.7	41.9

### 6 Pole

Frame	S4-40% 150S/H	S4-60%- 150S/H	S4-40%- 300S/H	S4-60%- 300S/H
	kW			
KD80	0.55	0.55	0.55	0.55
KD80	0.75	0.75	0.75	0.75
KD90S	1.1	1.1	1.1	1.1
KD90L	1.5	1.5	1.5	1.5
KD100L	2.2	2.2	2.1	2.1
KD112M	3.7	3.7	3.6	3.4
KD132S	5.5	5.5	5.3	5.1
KD132M	7.5	7.5	7.3	7.0
KD160M	9.3	8.9	9.0	8.7
KD160L1	11	10.6	10.7	10.2
KD160L2	15	14.4	14.6	14.0
KD180L	18.5	17.8	17.9	17.2
KD200L	22	21.1	21.3	20.5
KD225M	30	28.8	29.1	27.9
KD250M	37	35.5	35.9	34.5

For higher rating in 4 pole &amp; 6 pole and for 8 pole rating – refer to works.

## Performance Chart

Supply system - 415V+/-10%,50Hz+3/-6%,3-Phase

Ambient temp. - 45 Deg.C

Insulation – Class 'F'

Degree of protection - IP-55

Cooling - IC411

Duty - S4-40%CDF-150S/H

Factor of Inertia - 2 ( Load  $GD^2$  = Motor  $GD^2$  )

Type of start – DOL

Frame	kW	RPM	FLA ( Amps )	%Effy. (100 %) Load	P.f. (100%) Load	%Stg. Torque ( X FLT )	% POT ( X FLT )	% Stg. Current ( X FLA )	GD <sup>2</sup> ( Kgm <sup>2</sup> )
<b>4-POLE</b>									
KD71	0.55	1280	1.7	60	0.75	160	200	400	0.00255
KD80	0.75	1400	1.93	73	0.74	220	250	500	0.0064
KD80	1.1	1385	2.6	75	0.78	230	270	500	0.008
KD90S	1.5	1410	3.4	78.5	0.79	210	250	550	0.0156
KD90L	2.2	1414	5	80	0.77	240	275	600	0.0218
KD100L	3.7	1430	7.5	84	0.82	210	260	600	0.0516
KD112M	5.5	1435	10.6	85	0.85	250	300	600	0.0728
KD132S	7.5	1440	14.5	87	0.83	200	275	600	0.135
KD132M	9.3	1440	17.6	87	0.83	200	275	600	0.164
KD160M1	11	1450	20.1	88.5	0.86	220	275	600	0.177
KD160M2	15	1455	27.3	88.8	0.86	220	275	600	0.238
KD160L	18.5	1450	35	90	0.82	230	275	600	0.31
KD180M	22	1460	39	91	0.87	220	275	600	0.55
KD200L	30	1470	52.4	92.5	0.86	230	275	600	0.853
KD225S	37	1470	65	92.5	0.86	230	275	600	1.001
KD225M	45	1475	78	92.7	0.87	230	275	600	1.85
<b>6-POLE</b>									
KD80	0.55	900	1.9	65	0.61	190	230	400	0.0069
KD80	0.75	880	2.5	65	0.64	175	220	400	0.0097
KD90S	1.1	910	3	74	0.68	190	230	500	0.014
KD90L	1.5	925	3.9	75	0.72	210	260	450	0.0196
KD100L	2.2	925	4.9	79	0.8	180	230	550	0.05
KD112M	3.7	930	8.2	79	0.79	215	260	550	0.069
KD132S	5.5	950	11.9	83	0.77	200	260	600	0.15
KD132M	7.5	948	15	85	0.82	185	275	600	0.18
KD160M	9.3	965	18.6	86	0.81	225	260	600	0.299
KD160L1	11	965	25	85.5	0.72	250	280	600	0.299
KD160L2	15	968	30	88	0.78	220	250	600	0.378
KD180L	18.5	962	35	87.5	0.84	185	270	550	0.706
KD200L	22	980	44	90	0.77	220	250	600	1.105
KD225M	30	984	57	91	0.8	280	320	650	3.431
KD250M	37	985	69	91.5	0.82	285	300	650	3.676

POLICY : Every care has been taken to ensure the accuracy of the information contained in this publication but due to policy of continuous development and improvement the right is reserved to supply products which may differ slightly from those illustrated & described in this publication.



Specialized custom built motors • Specialists in short cycle deliveries

**Marathon Electric Motors (India) Limited Registered & Head Office:** 58, Taratala Road, Kolkata - 700024. LT Motor & Fan Factory, Paharpur Works, 58, Taratala Road, Kolkata - 700024, Fax: 9133 24695369 / 8530, Phone: 913344030400/033 44030431. Large LT Motor & HT Motor Factory, AEI Works, 1, Taratala Road, Kolkata - 700024, Fax : 9133 24696988. **MEMIL Regional Offices:** **New Delhi:** 516 & 518, Antriksh Bhawan; 22, K.G. Marg; Connaught Place; New Delhi - 110001; Tel: 011 - 43509363/64/65; Fax 011 - 43509367. Cell : 09717596620. **Chandigarh:** Chamber No. 8a, 2 Floor, Sco No. 2441-42, Sector 22-C; Tel: 09779024276. **Mumbai:** B-908/909 Sagar Tech Plaza, B-Wing, 9th Floor, Andheri Kurla Road, Sakinaka, Andheri(E) Tel: 9122 28523106, 09867605432, Fax: 22 30401555. **Pune:** 41/14, Office Club Swaroop Complex Karve Road; Tel: 9120 25463978, 09766623159; **Ahmedabad:** 415 / Platinum Plaza, Nr. Pushkar Tower, Judge-bunglow-Bodakdev Road; Tel: 9179 25602297, 09724507548. **Nagpur:** 1 Floor, Block A, Thapar Enclave, Plot No. 148, Ramdaspath; Tel: 91712 2526220, 09730032070. **Raipur:** 1 Floor, 141, Sundernagar, Near Adarsh Chowk; Tel: 91771 2210 240. 09752537535. **Chennai :** Door No. 9, Flat No. 7, 1 Floor, Thiru. Vi. Ka. Road, Royapettah, (opp, Sathyam Theatre), Tel: 9144 43510152, 09790999037, Fax: 044 43510153. **Secunderabad:** Cabin No. 47, 303, Swapnalok Complex, 92, S. D. Road; Tel: 9140 27812724, 09701104446. **Bangalore :** C1-101, White House, 15 Cross, 6 Main R. T. Nagar; Tel: 9180 26558729, 09790999037. **Bhubaneswar :** 33, Budhanagar, Near Sunflower Nurshing Home, Bhubaneswar-751006; Tel: 09937002704. **Jamshedpur:** C/o. Mr. D. P. Ghosh, House No. 7, Bidyasagar Path, Uliyan, Kadma; Tel: 09934362014. **Product Enquiry:** 09903900828; [memi.mktg@marathonelectric.com](mailto:memi.mktg@marathonelectric.com). **24X7 Customer Service:** 09903900891/3/4, 9903058753, 03344030409/414-wkdays; [kms@marathonelectric.com](mailto:kms@marathonelectric.com). **Marathon Electric India Private Limited:** Sector-11 Model Town, Faridabad - 12100 6 (INDIA), Tel: 91129 2286421/2265340; Fax: 91129-2284855, Email: [gemi.sales@regalbeloit.com](mailto:gemi.sales@regalbeloit.com)

[www.marathonelectric.in](http://www.marathonelectric.in)