



Smart solutions.
Strong relationships.

DC Motors

Cat No: LTM/Cat/01/Dec.2009



AVANTHA
GROUP COMPANY





DC Motors

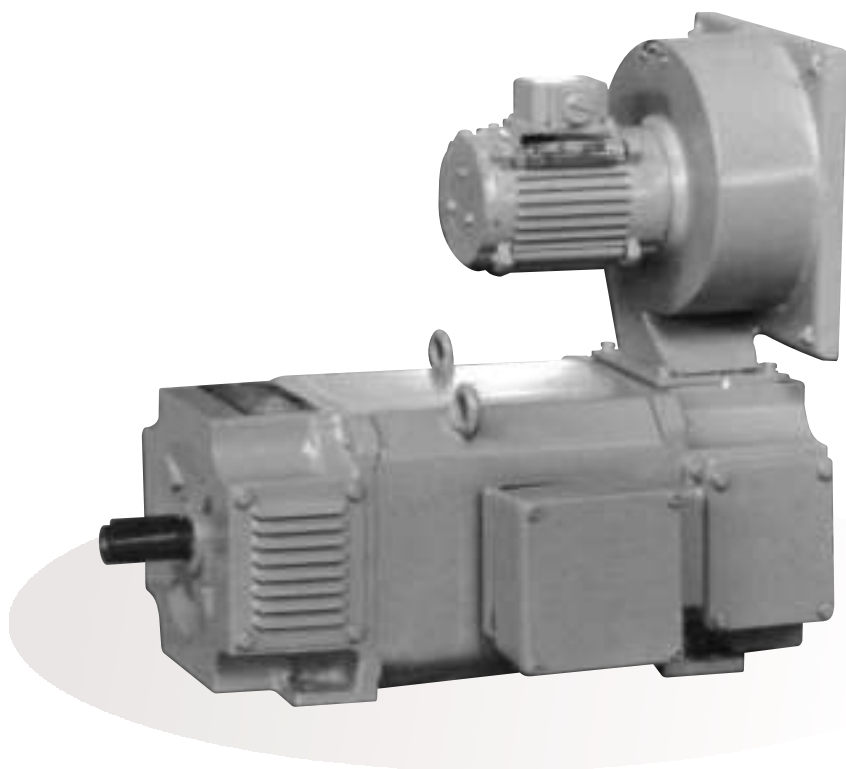

2.5 kW to 550 kW
From 100 to 315 Frame



INTRODUCTION

Crompton Greaves Ltd, a name synonymous with rotating machines have DC Motors Technology inherited from SIEMENS, Germany, the pioneer and world leader in DC Motors. Today, Crompton Greaves offers an entire range of world class DC Motors.

The motors are manufactured at Crompton Greaves Ltd. Ahmednagar factory, an ISO accredited set up having state - of - the - art manufacturing facilities. The high quality standards maintained in manufacturing and testing give superior electrical and mechanical features - making the motors most suitable for operating in tropical environments.



The Ahmednagar factory - manufacturing DC Motors

SPECIAL FEATURES

- Fully laminated yoke construction offering excellent commutation - suitable for 6 pulse thyristor power supply
- Skewed Rotor construction - ensuring low noise
- Vacuum pressure impregnation for armature winding - ensuring high insulation strength
- High dynamic response

APPLICATIONS

- Plastic Extruders
- Printing Machines
- Steel Rolling Mills and Wire Rod Mills
- Sugar Industry
- Textile Mills
- Apron Feeders
- Machine Tools
- Rubber Industry
- Cement Mills
- Cable Industry
- Paper Mills
- Material Handling



Laminated Yoke DC Motor manufactured at Ahmednagar

- Compact, low weight and highly energy efficient
- Larger size of bearings - for longer life and trouble free operations
- Constant / uniform pressure brush holders
- Easy fitting and retro-fitting of filters

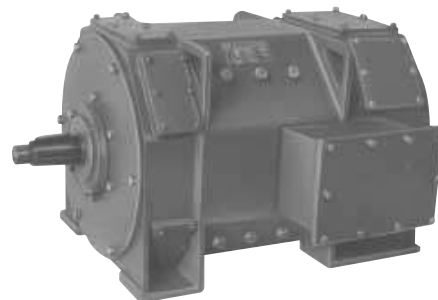

Aux Mill Duty DC Motors as per IPSS/AISE Standards are also manufactured



SPECIFICATIONS

**Laminated Yoke
Construction Range :**
Output : 2.5 kW to
550 kW
Frames : ASBG 100 to
ASBG 315

DESIGN PARAMETERS	STANDARD	OPTIONAL
ARMATURE VOLTAGE	440 V	MAX. 470 V UPTO FRAME 132, MAX. 600 V ABOVE FRAME 160
FIELD VOLTAGE	220 V	MAX. UPTO 500 V
EXCITATION TYPE	SHUNT	SERIES, COMPOUND
INSULATION	CLASS 'F' UPTO 132 CLASS 'H' ABOVE 160	CLASS 'H'
TYPE OF MOUNTING	B3	B35, V1, V3
DEGREE OF PROTECTION	IP 23	IP 54 WITH IC 37 (HEAT EXCHANGER)
ARRANGEMENT OF T. BOX	RHS FROM DE SIDE	ANY OTHER ARRANGEMENT
TACHO MTG. PROVISION	DTG 4000	ANY OTHER
TYPE OF MOUNTING OF BLOWER	TOP ON NDE SIDE	ANY OTHER LOCATION
AIR FLOW DIRECTION	FROM NDE TO DE	FROM DE TO NDE
AIR FILTER	NIL	DRY TYPE FILTER (RECOMMENDED FOR DUSTY ENVIRONMENT)
AIR FLOW SWITCH	NIL	VENTCAPTOR AIR FLOW MONITOR
BEARINGS	BALL BEARINGS	ROLLER BEARING ON DE SIDE
SHAFT END	WITH KEYWAY, BALANCING WITH FULL KEY	DOUBLE SHAFT EXTENSION WITHOUT TACHO MOUNTING ARRANGEMENT
SPACE HEATER	NIL	230 V, 1 PH
THERMISTER	NIL	FOR TRIP. FOR ALARM AND TRIP
PAINT FINISH	631 OF IS:5	PRIMER ONLY / ANY OTHER SHADE

BRUSH LIFETIME

FRAME	TIME IN Hrs.
Upto 160	15000
180	14000
200	12500
225	11000
250	11000
280	11000

BRUSH MATERIAL,
COMMUTATION :
Practically sparkless
commutation with converter
feeding, even under overload
conditions is achieved. As a
result, the brushes have an
extremely long life.

NOISE LEVEL

FRAME	MEASURING SURFACE SOUND PRESSURE LEVEL IN dB(A) *
100	<70 dB
112	<70 dB
132	<70 dB
160	<75 dB
180	<75 dB
200	<75 dB
225	<85 dB
250	<85 dB
280	<85 dB

The noise levels of the motors have been calculated in accordance with DIN EN 21 680 and are well below the values permitted by EN 60034 - 9. They have been achieved both by means of design measures and by optimising the magnetic circuit and the separately driven fans.

*** At No Load, with blower ON, with thyristor supply**

FORCED COOLING DETAILS

FRAME	COOLING AIR FLOW IN m ³ /sec	REQUIRED PRESSURE HEAD IN miliBar
ASBG 100	0.06	5
ASBG 112	0.07	5
ASBG 132	0.09	5
ASBG 160	0.20	13
ASBG 180	0.30	13
ASBG 200	0.35	13
ASBG 225	0.50	16
ASBG 250	0.60	16
ASBG 280	0.75	16

The blowers of DC Motors have three phase motors with wide range of winding and supply voltages. The blower motors are selected strictly in accordance with the air quantity required and ensures cool running of motors under the specified operating loads / overloads. The terminal box of blower motors are easily assessable.

FILTER MOUNTING :

A dry type air filter can be mounted or retro-fitted on all the DC Motors without derating.



TECHNICAL DATA

RATED OUTPUT IN KW AT 1500 RPM	FRAME	RATED TORQUE IN Nm	RATED ARM. CURRENT	EFFICI- ENCY	FIELD POWER IN watt	MAX. FIELD WEAKENING SPEED	MAX. SAFE MECH. SPEED	MOMENT OF INERTIA IN kg-m ²	WEIGHT IN kg
2.5	ASBG100S	16	7.7	67	330	3350	5000	0.016	50
3.7	ASBG100M	24	11.2	70	330	3250	5000	0.02	61
5.5	ASBG100L	35	16	74	440	3100	5000	0.025	76
7.5	ASBG112M	48	21	78	363	3750	4500	0.042	115
11	ASBG132S	70	31	77	616	2400	4500	0.09	125
15	ASBG132M	95	41	80	616	2400	4500	0.11	145
18.5	ASBG132L	118	48.2	83	968	2200	4500	0.14	170
22.5	ASBG132L	143	59	84	968	2200	4500	0.14	170
30	ASBG160A	191	78	83	1694	3000	4000	0.29	290
40	ASBG160S	255	105	84	1232	2350	4000	0.32	320
56	ASBG160M	356	147	85	1254	1950	4000	0.38	365
60	ASBG160L	382	158	85	1474	3000	4000	0.46	428
70	ASBG180S	446	176	88	2310	3400	3500	0.6	460
80	ASBG180S	509	201	88	2310	3300	3500	0.7	520
100	ASBG180M	637	253	88	2376	3300	3500	0.7	520
115	ASBG200S	732	291	88	2420	2800	3000	1.2	610
125	ASBG200M	796	312	89	2640	3500	3000	1.3	690
135	ASBG200M	859	337	89	2640	3300	3000	1.3	690
150	ASBG200M	955	374	90	2640	3100	3000	1.3	690
158	ASBG200M	1006	394	90	2640	3100	3000	1.3	690
160	ASBG225S	1018	400	89	2860	2460	3000	2.2	880
180	ASBG225S	1146	441	91	2860	2650	3000	2.5	990
210	ASBG225M	1337	513	92	3190	2320	3000	2.5	990
225	ASBG225M	1432	552	91	3190	2320	3000	2.5	990
235	ASBG250S	1496	571	92	3300	2250	2500	3.6	1160
270	ASBG250S	1719	658	92	3300	2025	2500	3.6	1160
280	ASBG250S	1782	682	92	3300	1980	2500	3.6	1160
295	ASBG250S	1878	719	92	3300	1980	2500	3.6	1160
325	ASBG250M	2069	790	93	3520	1990	2500	4.2	1320
400	ASBG280S	2546	965	93	4752	1710	2500	6.4	1560
450	ASBG280M	2864	1080	94	4180	1710	2500	7.5	1780

DC Motors



DIMENSIONS

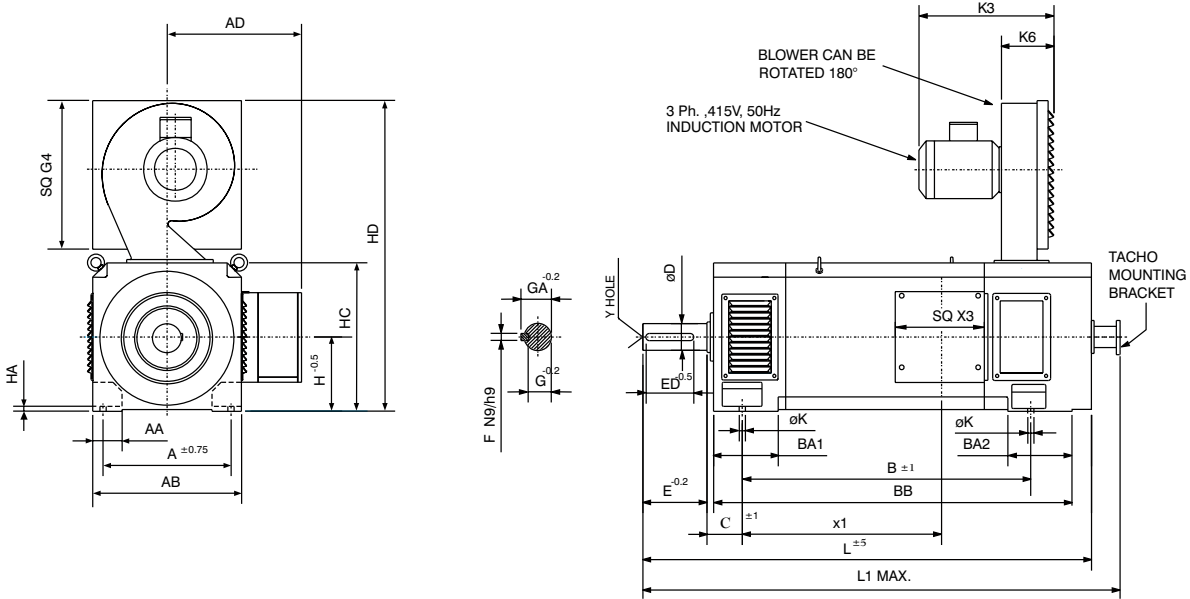

FRAME	SHAFT EXTENSION DETAILS								FOOT HOLE DIMENSIONS								OVERALL DIMENSIONS						BLOWER DIMENSIONS				
	H	D	F	G	GA	E	ED	Y	A	AA	AB	B	BA1	BA2	BB	C	HA	K	AD	HC	HD	X1	L	L1	K3	K6	G4
ASBG 100S	100	28	8	24	31	60	50	M10X24	160	40	198	257	60	60	290	63	9	12	190	200	445	120	460	535	235	100	220
ASBG 100M												305			340												
ASBG 100L												369			405												
ASBG 112S	112	38	10	33	41	80	70	M12X28	190	40	220	340	100	60	420	70	10	12	220	222	470	230	585	655	235	100	220
ASBG 112M												400			480												
ASBG 132S	132	42	12	37	45	110	90	M16X32	216	45	258	320	125	75	425	89	11	12	245	260	545	175	640	710	240	100	255
ASBG 132M												370			475												
ASBG 132L												430			535												
ASBG 160A	160	60	18	53	64	140	125	M20X42	254	55	316	530	140	125	630	70	12	14	305	318	680	245	785	852	355	120	310
ASBG 160S												590			690												
ASBG 160M												660			760												
ASBG 160L												750			850												
ASBG 180S	180	65	18	58	69	140	125	M20X40	279	65	360	600	110	130	730	121	14	15	350	360	740	370	1020	1085	475	185	350
ASBG 180M												670			800												
ASBG 200S	200	70	20	62.5	74.5	140	125	M20X40	318	80	400	645	120	185	815	133	18	19	370	400	780	390	1090	1160	475	185	350
ASBG 200M												725			895												
ASBG 225S	225	80	22	71	85	170	140	M20X40	356	85	450	735	140	200	925	149	18	19	430	450	980	475	1290	1355	550	215	430
ASBG 225M												825			1015												
ASBG 250S	250	90	25	81	95	170	140	M24X50	406	95	500	785	150	240	1015	168	22	24	455	500	1030	530	1420	1490	530	215	430
ASBG 250M												885			1115												
ASBG 280S	280	95	25	86	100	170	140	M24X50	457	100	560	850	160	230	1100	190	22	24	485	560	1090	585	1500	1565	530	215	430
ASBG 280M												960			1210												

Note : For Nonstandard motor, refer to Works.

AUX MILL DUTY D.C. MOTORS TO AISE/IPSS STANDARDS

Crompton Greaves Ltd., a name synonymous with rotating machines backed by its long proven expertise in the field of DC motors offers the entire range of state of art Auxiliary Mill Duty 800 series DC motors in frames 802 to 818 from 7.5 kW at 900 RPM to 187 kW at 435 RPM to AISE/IPSS Standards.

These motors are very rugged, reliable and suitable for steel mills or like applications.

818, 816, 814, 812, 810, 808, 806, 804, 803 & 802 frames are manufactured at CGL, LT Motors Division, Ahmednagar (Lam yoke DC motor frames 100 to 280 are also manufactured here). M3 Division is accredited with **ISO 9001 Certification** by BVQI for Quality Management System.

SALIENT FEATURES

- Conforming to AISE technical report no. 1-1991 / IPSS 1-03-002-94.
- Full speed, half speed and quarter speed designs available.
- Suitable for operations upto 500 volts.
- Suitable for operation on 3 phase, 6 pulse thyristor converter.
- Class 'H' insulation with class 'F' temperature rise limits.
- Armature class 'H' with VPI in solventless polyesterimide resin.
- TIG welding of armature coil connection to commutator.
- Split / Non split yoke without compensating winding or non split laminated yoke with compensating winding. However split yoke is preferred for 808 & above frames and compensating type for 812 & above frames.
- Replaceable shaft.
- Double shaft extension 1:9.6 taper with key way parallel to taper as per AISE or 1:10 taper with key way parallel to shaft axis as per IPSS.
- Convertible between TENV & TEFV enclosure or with top mounted blower unit.
- Loose hanging leads or terminal box as required.
- Axial play of 3 mm approximately of shaft.
- Brush position of 45 deg. for easy access for maintenance (except in case of laminated yoke version).
- Motor mounting dimension can be matched to replace 600 series motors to AISE or Russian standard.

STANDARD DATA OF MILL DUTY FRAMES 802 TO 818 AS PER AISE TECH REPORT 1

FRAME	KW RATING FORCED VENTILATED CONTINUOUS TENV ONE HOUR	BASE SPEED (RPM) AT 230V			ADJUSTABLE SPEED	SAFE SPEED (MECH) RPM	ROTOR GD SQ KGM SQ	APPROX TOTAL WEIGHT KG
		SHUNT	COMP	SERIES				
802C	7.5	900	900	800	900 / 1800	3600	0.8	300
803	11	800	800	725	800 / 2000	3300	1.5	400
804	15	725	725	650	725 / 1800	3000	2.6	500
806	22	650	650	575	650 / 1950	2600	4.5	700
808	37	575	575	525	575 / 1725	2300	8	900
810	52	550	550	500	550 / 1650	2200	15	1200
812	75	515	515	475	515 / 1300	1900	23	1600
814	112	500	500	460	500 / 1250	1700	36	2200
816	150	480	480	450	480 / 1200	1600	56	3000
818	187	435	435	410	435 / 1100	1500	85	3700

DC Motors

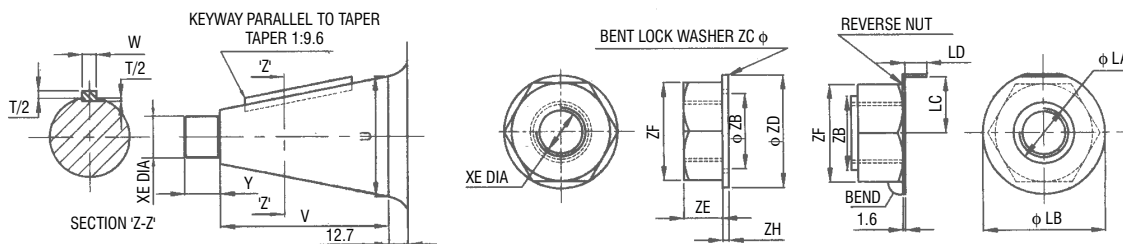
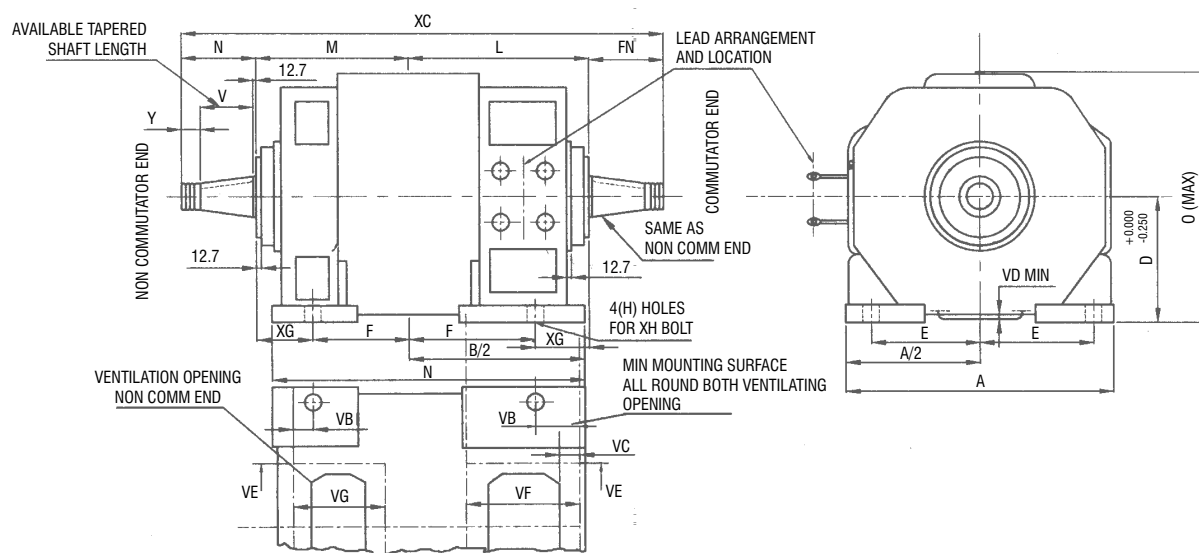

FRAME SIZE	A	B	XC	D	E	F	XG	H	XH	LM	O
802	381	520.7	835.02	193.68	158.75	209.55	92.25	24	M20	304.8	400
803	431.8	596.9	939.8	215.9	177.8	228.6	114.3	28	M24	342.9	445
804	457.2	647.7	990.6	228.6	190.5	241.3	127	28	M24	368.3	470
806	508	698.5	1073.15	254	209.55	266.7	127	28	M24	393.7	521
808	577.9	793.8	1206.5	285.75	238.13	314.32	130.17	35	M30	444.5	584
810	622.3	825.5	1276.36	311.15	260.35	330.2	146.05	35	M30	476.25	635
812	685.8	914.4	1397	339.73	285.75	361.95	158.75	35	M30	520.7	692
814	762	1054.1	1543.05	374.65	317.5	406.4	184.15	42	M36	590.55	762
816	825.5	1187.45	1714.5	406.4	342.9	444.5	215.9	42	M36	660.4	829
818	914.4	1263.65	1793.88	450.85	381	495.3	203.2	48	M42	698.5	918

SHAFT				KEY				SHAFT NUT AND LOCK WASHER					
N FN	U	V	Y	XE	WIDTH	THK	ZB	ZC	ZD	ZE	ZF	ZG	ZH
112.71	44.45	69.85	30.16	M30X2	12.7	12.7	35	36	58.2	22	48	6	4.5
127	50.8	82.55	31.75	M36X3	12.7	12.7	41	42	68.2	24	55	7	5.5
127	50.8	82.55	31.75	M36X3	12.7	12.7	41	42	68.2	24	55	7	5.5
142.87	63.5	95.25	34.93	M42X3	12.7	12.7	47.5	48	75	27	65	7	5.5
158.75	76.2	107.95	38.1	M48X3	19.05	12.7	51.5	52	83	30	75	8	6.5
161.93	82.55	107.95	41.28	M56X4	19.05	12.7	59.5	60	91	32	85	8	6.5
177.8	92.075	120.65	44.45	M64X4	19.05	12.7	71.5	72	103	36	95	8	6.5
180.96	107.95	120.65	47.63	M80X4	25.4	19.05	89.5	90	121	40	115	8	6.5
196.85	117.475	133.35	50.8	M90X4	31.75	19.05	99.5	100	131	632	130	8	6.5
198.44	127	146.05	39.69	M100X4	31.75	25.4	109.5	110	141	40	145	8	6.5

VENT DUCT FLANGE						SURFACEBEND LOCK PLATE				BEARING NO. (BOTH SIDE)
VB	VC	VD	VE	VF	VG	LA	LB	LC	LD	
22.2	9.5	9.5	184.2	120.7	55.6	31.5	63.5	25.4	6.4	NJ310
44.5	12.7	9.5	215.9	127	82.6	37.5	73	28.5	8	NJ311
57.2	12.7	9.5	228.6	139.7	69.9	37.5	73	28.5	8	NJ313
54	12.7	9.5	260.4	152.4	85.7	43.5	92.1	31.8	14.3	NJ315
50.8	12.7	19	292.1	165.1	88.9	49.5	109.5	38.1	16.7	NJ317
54	12.7	19	304.8	177.8	92.1	57.5	120.7	41.3	19	NJ319
63.5	15.9	19	349.3	209.6	123.8	65.5	127	47.6	15.9	NJ321
85.7	15.9	19	387.4	235.0	139.7	81.5	149.3	56.3	18.3	NJ324
114.3	25.4	19	406.4	279.4	168.3	91.5	165.5	66.7	15.9	NJ326
98.4	25.4	19	457.2	304.8	180.98	101.5	171.5	66.7	19	NJ328

Notes :

1. Shaft Extension threading can be of inch series on request.
2. Terminal Box can be provided on request.
3. Motors with force cooling unit or heat exchangers also can be given on request.
4. Generally conform to A.I.S.E. STD.1. Can be given to I.P.S.S.1-03-002-94 standard also.
5. Laminated type of construction can be offered on request (with blower or without blower).

Northern Region Sales Office :

New Delhi :

Vandana, 11, Tolstoy Marg, New Delhi - 110 001
Phones : (011) 30416300

Jalandhar :

416-417, 3rd Floor, Prestige Chambers,
GT Road, Jalandhar - 144 001
Phones : (0181) 3240990

Lucknow :

Saran Chambers II, 3rd Floor, 5 Park Road,
Lucknow - 226 001
Phones : (0522) 3018850

Jaipur :

Church Road, P. O. Box. No. 173, Jaipur-302 001
Phones : (0141) 3018800

Eastern Region Sales Office :

Kolkata :

50, Chowringhee Road, Kolkata - 700 071
Phones : (033) 22829681-85

Bhubaneshwar :

Janpath Tower, Third Floor,
Ashok Nagar, Unit II,
Bhubaneshwar - 751 009
Phones : (0674) 2531128

Western Region Sales Office :

Mumbai :

Kanjur Marg (E), Mumbai-400 042.
Phones : (022) 67558000

Ahmedabad :

909-916, Sakar II, Near Ellis Bridge Police Station,
Ahmedabad - 380 006
Phones : (079) 40012000

Pune :

Premium Point, 4th Floor, Opp. Modern High School,
Jangali Maharaj Road, Pune 5.
Phones : (020) 25534675-77

Indore :

103-B, Apollo Trade Centre, 2B, Rajgarh Kothi,
Mumbai-Agra Road, Indore - 452 001.
Phones : (0731) 2498269

Nagpur :

3, West High Court Road, Lal Bahadur Shastri Chowk,
Dharampath, Nagpur - 440 010
Phones : (0712) 2531271

Raipur :

5, New Tilak Nagar, Near Sai Care Hospital,
Avanthi Bihar Colony, Raipur.
Phones : (0771) 4022215

Southern Region Sales Office :

Chennai :

No.3-A, MGR Salai, Kodambakkam High Road,
Nungambakkam,
Chennai - 600 034.
Phones : (044) 42247500

Bangalore :

1st Floor, Janardhana Towers, 562/640,
Bannerghetta Road, Bilekahalli, Bangalore 560 076.
Phones : (080) 41391908

Cochin :

Cherupushpam Building, 5th Floor, 300-6
Shanmugham Road, Ernakulum, Cochin - 682 031.
Phones : (0484) 2370860

Secunderabad :

4th Floor, Minerva House, 94, Sarojini Devi Road,
Secunderabad - 500 003.
Phones : (040) 40002300

Regional Service Centres :

North : Vandana, 11, Tolstoy Marg, New Delhi-110 001. Phones: (011) 30416308.

East : 21, R.N.Mukherjee Road, Kolkata-700 001. Phones: (033) 22489160.

West : Kanjur Marg (E), Mumbai 400 042. Phones : (022) 67558590.

South : 3A, MGR Salai, Kodambakkam High Road, Nungambakkam, Chennai-600 034. Phones : (044) 23651369.

NOTE : As the design and manufacture of Crompton Greaves electrical equipment are subject to constant improvement,, the product supplied may differ in some details from the specifications and illustrations given in this booklet.
For more details, contact Works.

Crompton Greaves Limited

LT Motors Division

Manufacturing Units :

Ahmednagar Works :

A-6/2, M.I.D.C. Industrial Area, Ahmednagar - 414 111.

Tel.: (0241) 2776 150 - 157. Fax : (0241) 2777508, 2777800.

Goa Works :

S-14/15, Colvale Industrial Estate, Colvale, Bardez, Goa - 403 513.

Tel.: (0832) 2299664 / 665 / 666 Fax: (0832) 2299663.

Registered Office :

CG House, 6th Floor, Dr. Annie Besant Road, Worli, Mumbai - 400 030. India.

W : www.cgglobal.com